



Digital Tachograph SE5000

STONERIDGE – SETTING THE STANDARD



User Manual 



Certified User Manual



This User Manual is an extended version of the certified user manual 9000-101587/01R06, and have been produced to meet the demands of our customers.

The certified version can be found on the Internet at:

www.stoneridgeelectronics.info

Thank you for choosing Stoneridge SE5000 tachograph.

We recommend that you familiarise yourself with how to operate your digital tachograph before starting your first journey.

Please read this User Manual before driving off. This will help you to obtain the maximum use from your tachograph and avoid endangering yourself and others.

Stoneridge Electronics reserves the right to introduce changes in design, equipment and technical features at any time. You cannot, therefore, base any claims on the data, illustrations or descriptions in these operating instructions.

Your local Stoneridge Representative will be happy to assist if you should have any further questions.

You should always keep this User Manual in the vehicle. If you sell the vehicle you should pass this manual on to the new owner, as the tachograph is seen as a part of the vehicle.

The technical documentation team at Stoneridge Electronics wishes you pleasant and safe motoring.

Symbols



Warning



Important information



Tip



Action required



Sequence of actions
(several ►)



Page reference

Display

Messages in the display

Definitions in these instructions

Driver 1

The person who is currently or will be driving the vehicle.

Driver 2

The person who is not driving the vehicle.

Working day

A number of activities carried out by Driver 1 and Driver 2.

Activity

With what is the driver occupied.

Contact Stoneridge

You are welcome to forward any queries or suggestions you may have about the tachograph and the operating instructions to any of our sales offices, as listed below.

France

Stoneridge Electronics France
Zone Industrielle De St Etienne
Chemin De Cazenave
F-64100 Bayonne
France

Tel. +33 (0)5 59 50 80 46
Fax. +33 (0)5 59 50 80 41

e-mail: france.amsales@elc.stoneridge.com

Germany / Deutschland

Stoneridge GmbH
Paradiesweg 11
D-73733 Esslingen
Germany

Tel. +49 (0)711-99 33 82-0
Fax. +49 (0)711-99 33 82-12

e-mail: sales@elc.stoneridge.com

Spain / España

Stoneridge Electronics España
Avda. Severo Ochoa 38
Pol. Ind. Casa Blanca
28108 Alcobendas
Madrid
Spain

Tel. +34 (0)91 662 32 22
Fax. +34 (0)91 662 32 26

e-mail: spain.amsales@elc.stoneridge.com

United Kingdom

Stoneridge Electronics Ltd
Charles Bowman ++Avenue
Claverhouse Industrial Park
Dundee, Scotland DD4 9UB

Tel. +44 (0)871 700 7070
Fax. +44 (0)870 704 0002

e-mail: sales@elc.stoneridge.com

Information on the Internet

Further information about
Stoneridge SE5000 tachograph
and about Stoneridge Electronics Ltd
can be found on the Internet at:

www.stoneridgeelectronics.info

Copyright

Not to be reprinted, translated or
otherwise reproduced in whole or
in part, without written permission
from Stoneridge Electronics Ltd.

i Please refer also to the index
 (▷ page 107)

Introduction

Operating safety	7
Repairs and modifications	7
Security inspection	7
Technical data	8

At a glance

Using the tachograph	10
Normal working day procedure	10
In case manual entries are needed	11
Temporary driving without driver card	11

System overview

Driver card	13
Vehicle unit (VU)	13
Display in the instrument cluster	13
Encrypted speed sensor	13

Vehicle Unit (VU)

VU standard display	16
VU main menu display	17

Working day activities

Working day definitions	18
Automatically selected activities	18
Activities selected manually	18
Activities without recording	19

Care for equipment	20
Care for driver card	20
Care for vehicle unit	20

Controls in detail

Normal working day procedure

Easy use of the tachograph	22
Power saving mode	22
Insert a driver card	23
Initial displays and entries	24
Three working day user scenarios ..	25
User scenario 1: New working day without previous activities	28
Change of activity during the working day	28
Withdraw a driver card	29

In case manual entries are needed ..

Manual entries overview	30
User scenario 2: Continuing present working day ...	32
User scenario 3: New working day with previous activities	33
Enter activity type and times	40
Enter the country	44
Modify manual entries	45
Exit manual entries mode	47

Contents

Journey with ferry or train	48	Care for vehicle unit	80
Enter before journey	48	Changing the paper roll	81
Journey where no recording is required	49	Remove the paper cassette	81
Driving out of scope	49	Insert a paper roll	82
Printouts	51	Troubleshooting and self-test	83
Create a printout	51	Self-test procedure	83
Types of printout	53	Appendix	
Printouts at a glance	55	Hazardous goods version / ADR	88
Settings	57	Special features of the ADR VU	88
UTC time	57	Data stored on driver card and in vehicle unit	90
Local time	58	Data stored on driver card	90
Display appearance	58	Data stored in vehicle unit	91
Displays and data		Responsible authorities	92
Displays	62	Available countries	99
Displays when in motion	62	National importers	101
Symbols	63	Index	
Messages, warnings and malfunctions	66	Index	107
Messages	66		
Warnings	66		
Malfunctions	67		
Practical advice			
Maintenance and care	80		
Replacement parts for printer	80		
Care for driver card	80		

Operating safety

Risk of accident



Do not operate the tachograph unless the vehicle is stationary. Your attention would otherwise be diverted from the road and traffic conditions and you could therefore cause an accident.

Bear in mind that, at a speed of only 50 km/h, your vehicle is covering a distance of nearly 14 m per second.

Repairs and modifications



The tachograph has been installed and sealed by authorised personnel. A vehicle unit case must never be opened. No tampering with or modifications to the equipment or the speed sensor are permitted.

Persons that modify this equipment may be committing a punishable offence, depending on the legislation in the country concerned.



- Have the tachograph checked at a specialist workshop if the outside is visibly damaged.
- High voltages may lead to permanent tachograph damage and to failure of the tachograph's electronic components. Damage to the tachograph caused in this way invalidates the warranty.



Interrupt the power supply to the tachograph if:

- electrical welding operations are to be carried out on the vehicle
- you expect that the vehicle will require several jump-starting attempts

Security inspection



The tachograph must be checked by a specialist workshop at least every 2 years.

The installation plaque, fixed next to the tachograph, states the date for passed security inspection.

All seals and the installation plaque must be intact for the security inspection.

Technical data

Operating temperature

–25 °C to +70 °C

Hazardous goods version in accordance with ADR: –25 °C to +65 °C

Certification and approval

The tachograph is approved for use in the European Union and certified to ITSEC “level E3 high” in accordance with EU legislation.

Type approval number: e5-0002

Electromagnetic compatibility

The tachograph fulfils the requirements of EU Commission Directive 95/54/EC in respect of electromagnetic compatibility.

Using the tachograph

System overview

Vehicle unit (VU)

Working day activities

Care for equipment

Using the tachograph

Normal working day procedure

During normal driving a driver card must be inserted in the VU. The driver is identified by the driver card and authenticated to drive after insertion.

Easy use of the tachograph

For the easiest use of the tachograph, enter all changes of activities at the time of respective change. The normal working day procedure will then be as follows:

- ▶ Insert a driver card at the beginning of a working day, before driving off.
- ▶ Press the  button (cancel).
- ▶ Enter all changes of activities at the time of respective change.

▶ Withdraw a driver card only at the time of:

- End of working day.
- Change of drivers.
- Change of vehicle.

(▶ Normal working day procedure, page 22)



The driver card is personal and may not be used by anyone else but the rightful card holder.



Drivers are responsible for ensuring that they obey driving laws.

Power saving mode

When the ignition is switched off, the VU will enter the power saving mode ten seconds after the last interaction with the VU.

During power saving mode the VU is not operational. The display information is still shown, but the display illumination is off.

The tachograph will be waked up and operational after you do either of the following:

- Press any button once.
- Insert a driver card.
- Start the vehicle.
- Take the vehicle in tow.

Using the tachograph

In case manual entries are needed

If you don't enter a change of activity at time of the change, it has to be entered manually at next insertion of driver card.

(▷ In case manual entries are needed, page 30)

Temporary driving without driver card



A driver without a valid driver card is not permitted to drive a vehicle equipped with this tachograph. Doing so would contravene EU regulations.

If the driver card is lost or damaged you have to request to the responsible authority, in the country where your driver card was issued, for:

- A temporary permit to drive without a driver card.
- A replacement card.

(▷ Responsible authorities, page 92)

If the driver card is stolen you also have to report to the police in the area where theft occurred and obtain a police report number.



If it is necessary to legally drive without a driver card, print out the “Daily activities from the VU” at the beginning and end of the working day

(▷ Create a printout, page 51).

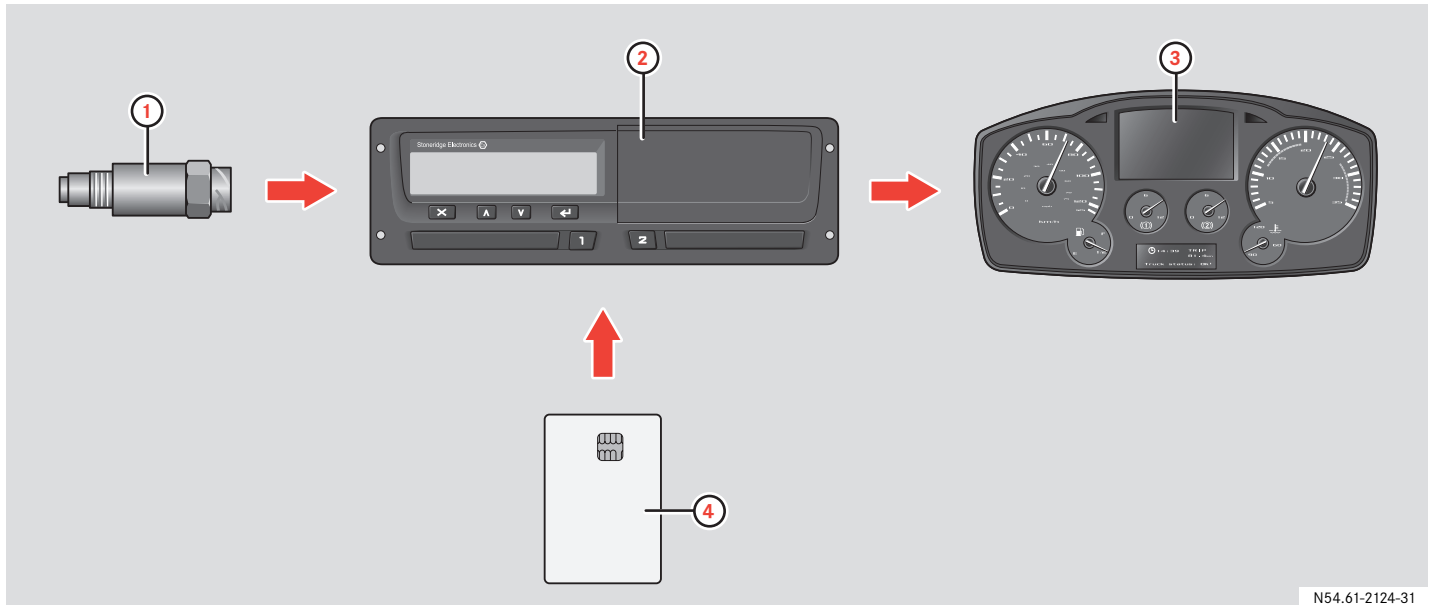

N54.61-2124-31

1 Encrypted speed sensor

2 Vehicle unit (VU) with integrated display and printer

3 Display in the instrument cluster

4 Driver card

System overview

Driver card

The driver card uniquely identifies the driver and stores various data under the driver's name:

- Driving times, activities and distance.
- Driver license information.
- Some events and malfunctions.
- Vehicle registration numbers for other vehicles used by the card holder.
- Controls performed by authorities.

Detailed information on driver card data (▷ Data stored on driver card, page 90).

The data can be shown on the integrated display and printed using the integrated printer.



The driver card can store data typically for up to 28 days. After this time, the oldest data record is cleared when new data is stored.

Vehicle unit (VU)

The vehicle unit (VU) records and stores various data:

- Driver card data, except from driving license data.
- Events and malfunctions relating to vehicle unit, driver, company and workshop.
- Vehicle information, odometer data and detailed speed.
- Tampering with the VU.

Detailed information on vehicle unit data (▷ Data stored in vehicle unit, page 91).

The data can be shown on the integrated display and printed using the integrated printer.



- Overspeeding for more than 1 minute is stored in the VU.
- All data is stored in Universal Time Coordinated (UTC). The local time also displayed in the VU is for information only.

Display in the instrument cluster

The instrument cluster displays the following information from the VU:

- Speed
- Distance travelled
- Messages, warnings and malfunctions

Encrypted speed sensor

The encrypted speed sensor measures speeds at the transmission and forwards them to the VU. Tampering with the sensor or the signal is detected by the tachograph and stored.

Vehicle Unit (VU)

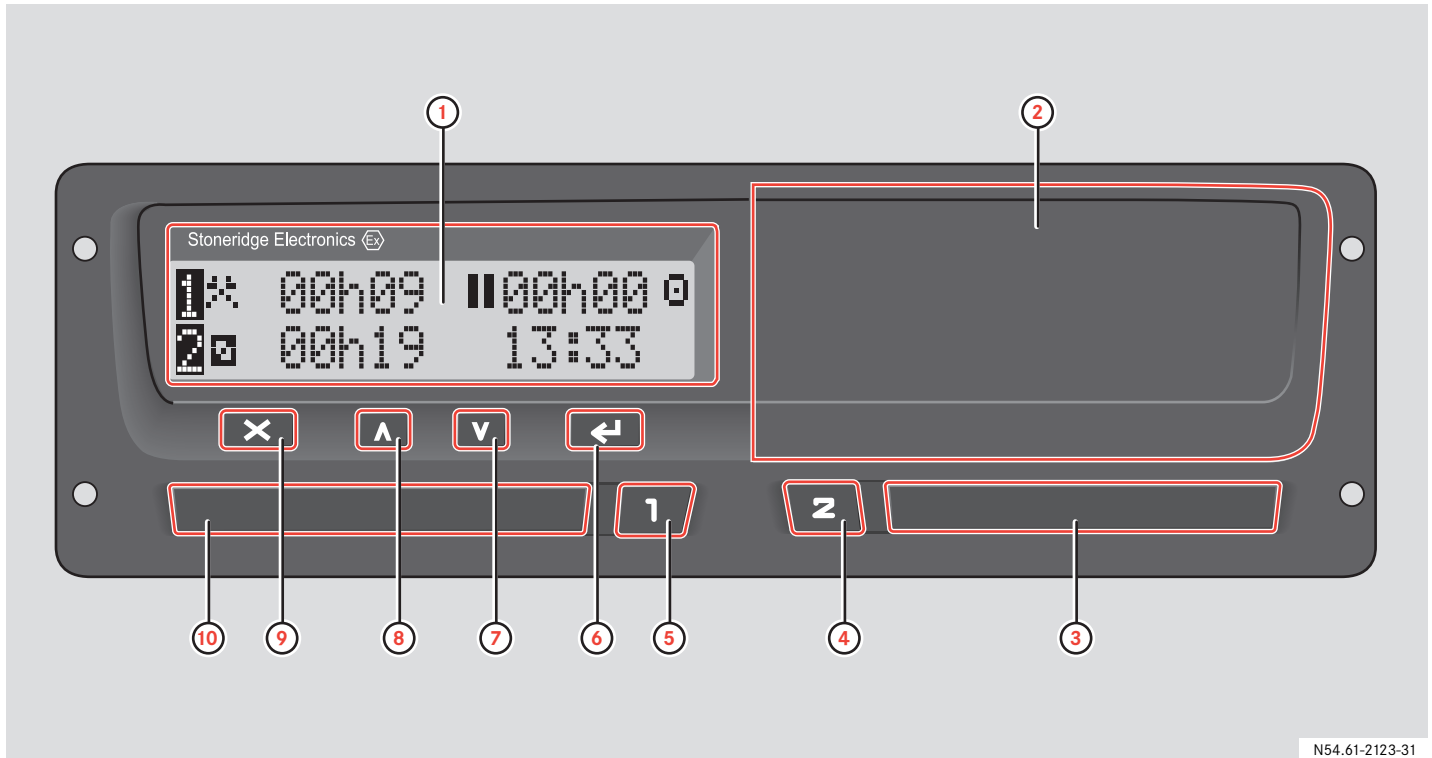

N54.61-2123-31

Vehicle Unit (VU)

	VU user interface	Page
1	Display	
	Standard display	16
	Main menu display	17
	To display messages	62
	To display warnings	66
	To display malfunctions	67
2	Paper cassette	
	To create a printout	51
	To insert/change a paper roll	81
3	Driver 2 driver card slot	
	To insert/withdraw the driver 2 driver card	22

	VU user interface	Page
4	Driver 2 button	
	To open the driver 2 driver card slot	23
	To change activities for driver 2	53
5	Driver 1 button	
	To open the driver 1 driver card slot	23
	To change activities for driver 1	53
6	Enter button	
	To confirm entries	-
	To acknowledge messages	66
	To acknowledge warnings	66

	VU user interface	Page
7	Down button	
	To decrease values	-
	To select options	-
8	Up button	
	To increase values	-
	To select options	-
9	Quit button	
	To cancel processes	-
	To return to the previous display	-
10	Driver 1 driver card slot	
	To insert/withdraw the driver 1 driver card	23

Vehicle Unit (VU)

VU standard display

The display changes to the standard display:

- As soon as the vehicle pulls away.
- By long pressing the  button.
- After completion of most manual entry procedures.

When the vehicle is in motion you can besides the standard display change to the:

- Speed display
- UTC time display
- Driving time and break time display
- Cumulative driving time display

(▷ Displays when in motion, page 62).

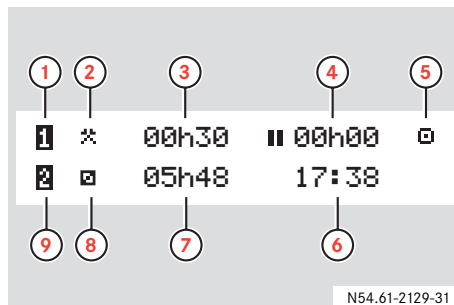

- 1 Driver 1
- 2 Activity of driver 1
- 3 Duration of activity of driver 1
- 4 Cumulative break time of driver 1 in a working day
- 5 Operating mode of the VU
- 6 Local time
- 7 Duration of activity of driver 2
- 8 Activity of driver 2
- 9 Driver 2

Main menu display

(▷ VU main menu display, page 17).

Other displays, symbols and combinations of symbols

(▷ Symbols, page 63).





Messages, warnings and notifications of malfunctions on the display

(▷ Messages, warnings and malfunctions, page 66).

Vehicle Unit (VU)

VU main menu display

Show the main menu display:

- ▶ Press the  button.
- ▶ Press the  or  button to scroll through the various main menu items.
- ▶ Press the  button to call up a specific menu item.

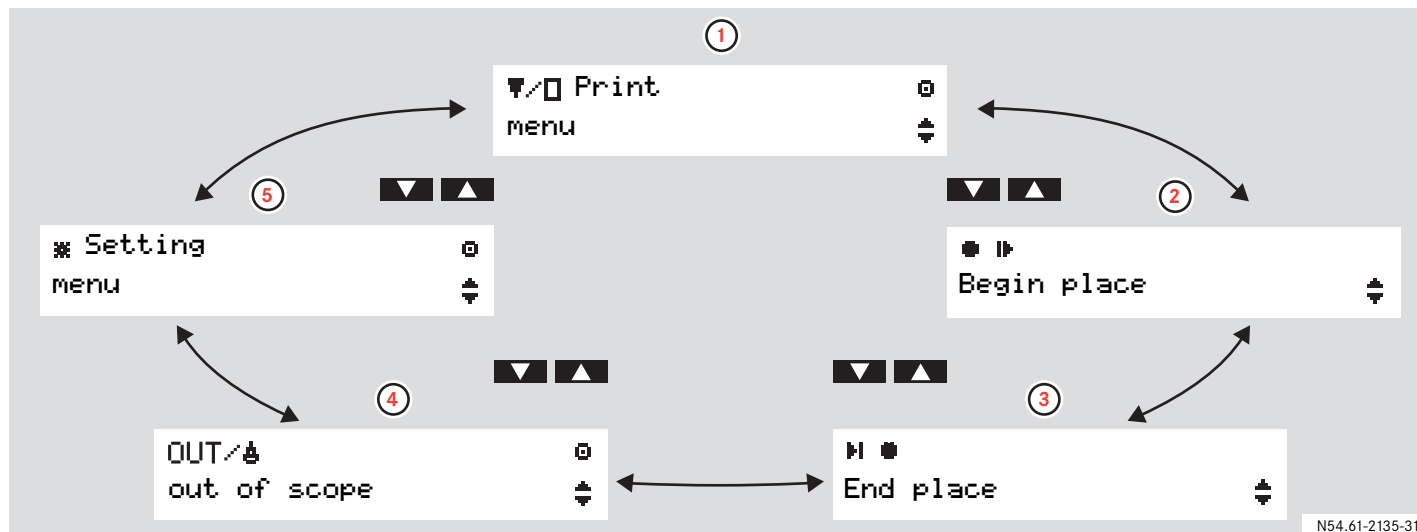

- 1** To create a printout (▷ page 51).
- 2** To enter the country in which work started (▷ page 44).
- 3** To enter the country in which work ended (▷ page 44).
- 4** To activate ferry / train or Out of scope mode (▷ page 48).
- 5** To change VU settings (▷ page 57).

Working day activities

Working day definitions

A working day is defined in the VU by the activities carried out by driver 1 and driver 2. Each activity has a start time and an end time. Some activities are selected by the VU automatically, others must be entered manually by the driver.

Symbol	Activity
⌘	Work Activity while the vehicle is not in motion, e.g. loading the vehicle
Ⓢ	Driving Driving the vehicle
⌚	Rest For breaks
Ⓜ	Availability Activity before the journey commences, e.g. filling out paperwork

Automatically selected activities

The VU selects the activity for each driver automatically according to the current driving situation.

Driving situation	Driver 1	Driver 2
Pulling away / driving	Driving	Availability
Stopping / stationary	Work	Availability



For Driver 1 the automatic change of activity is stored:

- from Driving to Work if the vehicle has been stationary more than two minutes.
- from Work to Driving if the vehicle has been driven within the last minute.

Activities selected manually

Any activity other than work for driver 1 or availability for driver 2 undertaken when the vehicle is stationary must be selected manually. The following activities can be selected manually:

- Rest
- Availability
- Work

To change activities during a working day (▷ Change of activity during the working day, page 28).

Working day activities

Activities without recording

If you are using the vehicle in conditions where the EU tachograph regulation 3820/85 does not apply, then recording of these activities is not required. This situation is called to drive “Out of scope”.

Out of scope driving could be, for example:

- Driving a vehicle that is only partly loaded in respect of weight, so that the vehicle gross weight does not exceed the limit at which a tachograph is required.
- Driving in a country outside EU.
- Driving on a non public road, for example driving in a gravel pit or off road.



Drivers are responsible for ensuring that they obey driving laws in respective country.

(▷ Driving out of scope, page 49)

Care for equipment

Care for driver card



- Do not flex or bend.
- Ensure that the card contacts are kept free from dirt.
- Clean with a soft damp cloth if necessary.
- Protect from theft, loss or other damage.

Care for vehicle unit



- Do not place objects on the slot trays when they are open, otherwise the trays could be damaged.
- The ingress of dirt can lead to premature failure of the VU. Keep the slots closed at all times and only open them to insert and withdraw the driver cards.
- Clean a dirty VU with a damp, soft cloth.

Normal working day procedure

In case manual entries are needed

Journey with ferry or train

Journey outside EU

Journey with no need for recording

Printouts

Settings

Normal working day procedure

Easy use of the tachograph

For the easiest use of the tachograph, enter all changes of activities at the time of respective change. The normal working day procedure will then be as follows:

- ▶ Insert a driver card at the beginning of a working day, before driving off.
(▷ Insert a driver card, page 23)
- ▶ Press the button (cancel):
(▷ User scenario 1: New working day without previous activities, page 28)
- ▶ Enter all changes of activities at the time of respective change:
(▷ Working day activities, page 18)
- ▶ Withdraw a driver card only at the time of:
 - End of working day.
 - Change of drivers.
 - Change of vehicle.(▷ Withdraw a driver card, page 29)



If you don't enter a change of activity at time, it has to be entered manually at next insertion of driver card.

(▷ In case manual entries are needed, page 30).

Power saving mode

When the ignition is switched off, the VU will enter the power saving mode ten seconds after the last interaction with the VU.

During power saving mode the VU is not operational. The display information is still shown, but the display illumination is off.

The tachograph will be waked up and operational after you do either of the following:

- Press any button once.
- Insert a driver card.
- Start the vehicle.
- Take the vehicle in tow.

Normal working day procedure

Insert a driver card

In two-man operation, the driver that will begin driving inserts his driver card into the slot for driver 1. The second driver inserts his card into the slot for driver 2.



The driver cards must be swapped in their slots if there is a change of drivers.

The slots are locked while the vehicle is in motion and can only be opened:

- when the vehicle is stationary
- with key-on, in case of ADR vehicle (▷ Special features of the ADR VU, page 88).



The **1** and **2** buttons are disabled:

- While the VU is busy processing a driver card.
- If the power supply to the VU is interrupted. If the power supply cannot be re-stored, it will be necessary to have the slot unlocked at a specialist workshop for tachographs.

Description of displays, symbols, messages or warnings:

(▷ Displays, page 62).

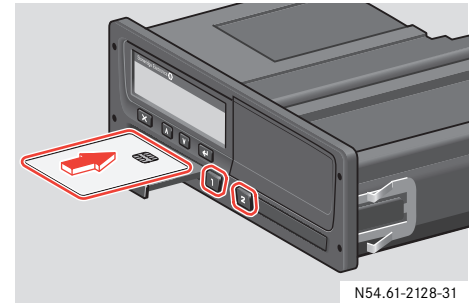

N54.61-2128-31

- ▶ Press and hold the **1** button for the driver 1 driver card slot or the **2** button for the driver 2 driver card slot.
- ▶ Insert the driver card with the chip facing upwards.
- ▶ Close the slot by pressing it carefully. The VU now processes the driver card data. This may take up to a minute. (▷ Initial displays and entries, page 24).

Normal working day procedure

Initial displays and entries

After having inserted a driver card the VU processes the driver card data. This may take up to a minute.

```
1          Busy
          processing  ⌘
```

When a driver card has been authenticated, the name of the card holder is displayed.

```
1 Ⓞ Smith
John
```

Information about last driver card withdrawal time is shown for a short time.

If your driver card was last withdrawn from the VU more than 24 hours ago, you will be displayed a warning

(▷ Last withdrawal time warning, page 24).

Then you are asked if this is a continuation of a working day:

```
▷? MCont. day.?  ✓
15:23 08.07.2005  ✕
```

Last withdrawal time warning

```
>24h Ⓞ + Last card
withdrawal >24h.
```

This warning is displayed if your last withdrawal of driver card was done more than 24 hours ago.

- ▶ Acknowledge the message.
- ▶ The VU automatically finishes last working day and creates a new working day. Manual entries are required.

(▷ User scenario 3: New working day with previous activities, page 33).

Further information about warnings:
(▷ Messages, warnings and malfunctions, page 66).

Normal working day procedure

Three working day user scenarios

Initially you have three options of entries to continue, with corresponding main user scenarios.

- User scenario 1:
Press the button (cancel)
- User scenario 2:
Select (yes):
- User scenario 3a, 3b or 3c:
Select (no).

Normal working day procedure

User scenario 1

Press the button (cancel):

- This is a new working day without previous activities, neither after last driver card withdrawal, nor before this insertion.
- No need for manual entries.

(▷ User scenario 1: New working day without previous activities, page 28).

User scenario 2

Select (yes):

- You are continuing the present working day, but you have for a period worked with no driver card inserted.
- Manual entries are needed
(▷ Manual entries overview, page 30).

(▷ User scenario 2: Continuing present working day, page 32)

User scenario 3a, 3b or 3c

Select (no):

- This is a new working day with previous activities. You have either:
 - 3a. Started this working day, or
 - 3b. Finished last working day, or
 - 3c. Finished last working day AND started this working day,

with no driver card inserted.
- Manual entries are needed
(▷ Manual entries overview, page 30).

(▷ User scenario 3: New working day with previous activities, page 33)

Normal working day procedure

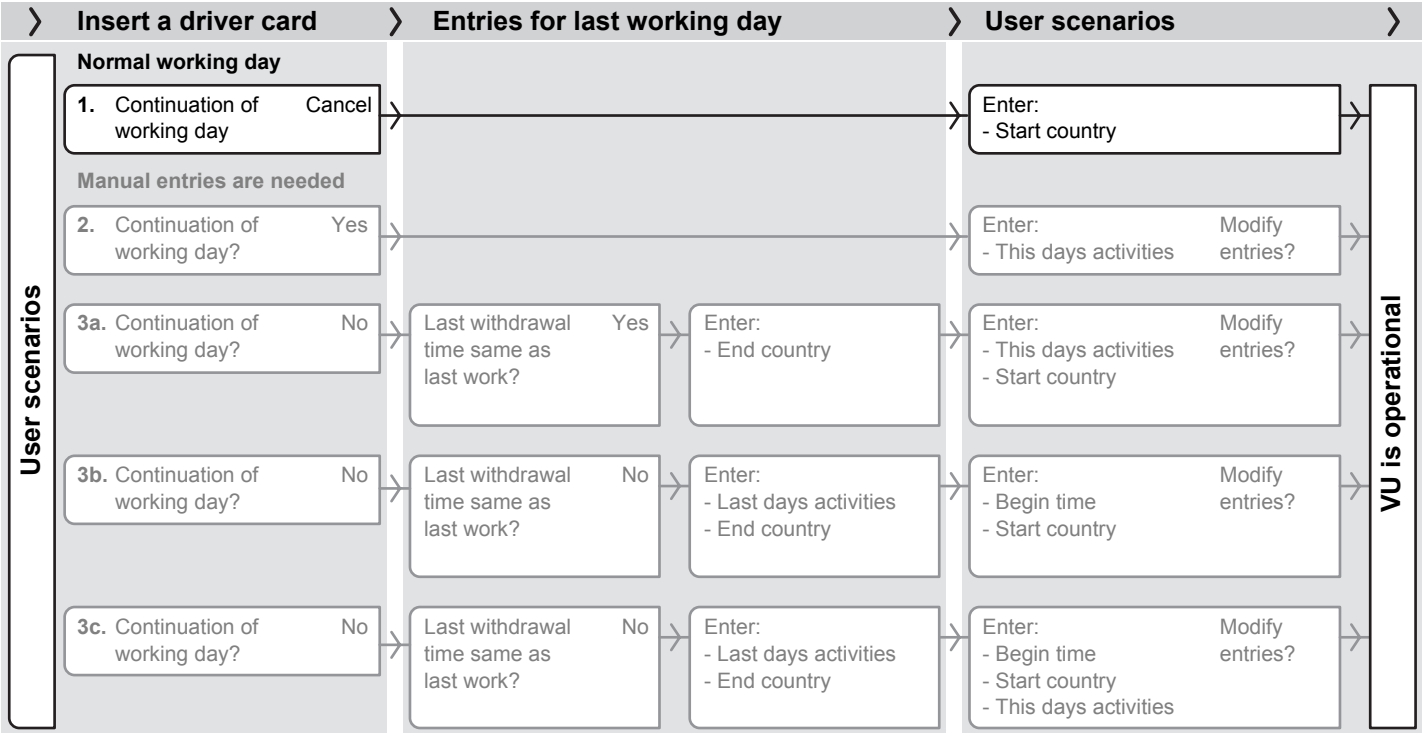

N54.61-2133-31

Normal working day procedure

User scenario 1: New working day without previous activities

This is a new working day without previous activities, neither after last driver card withdrawal, nor before this insertion. No need for manual entries.

- ▶ Press the button (cancel).
The VU stores the time of the last card withdrawal as the end of the last working day and creates a new working day.
- ▶ Enter the country in which you are currently present.

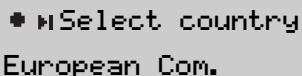

* Select country
European Com.

The VU is now operational and you will see the standard display.

(▷ VU standard display, page 16).

Change of activity during the working day

The normal way to enter change of activity during a working day, for example when you have been driving and will go for lunch, is to:

- ▶ Stop driving the vehicle.
- ▶ Depending on the driver, press the or button repeatedly until the desired activity is shown in the display.

Definition of activities

(▷ Working day activities, page 18)



Change of activity can be made only when the vehicle is stationary.



Normal working day procedure

Withdraw a driver card



The driver cards remain in the slots of the VU for the entire duration of the working day. They are withdrawn only at the end of the working day or if there is a change of drivers.

To withdraw a driver card:

- ▶ Press and hold the  button for the driver 1 driver card slot or the  button for the driver 2 driver card slot.
- ▶ Enter the country in which you are currently present.
(▷ Enter the country, page 44).
- ▶ Press the  button.

The VU stores data on the driver card and opens the slot.

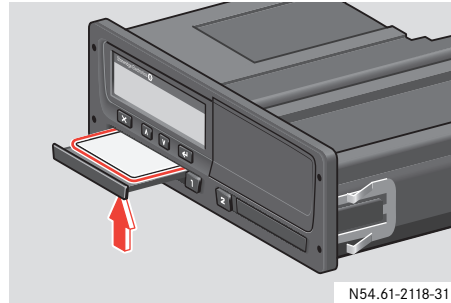

N54.61-2118-31

- ▶ Press the driver card up slightly from underneath through the opening in the tray.
- ▶ Remove the driver card.
- ▶ Close the slot by pressing it carefully.

Ejecting
card 1



In case manual entries are needed

Manual entries overview

Manual entries are needed in case a change of activity has not been entered at the time of the change.

You have to manually enter these activities at next insertion of driver card.



For the easiest use of the tachograph, enter all changes of activities at the time of respective change for each driver.

(▷ Normal working day procedure, page 22)

(▷ User scenario 1: New working day without previous activities, page 28)

User scenario 2

You are continuing the present working day, but you have for a period worked with no driver card inserted.

(▷ User scenario 2: Continuing present working day, page 32).

User scenario 3a, 3b or 3c

This is a new working day with previous activities. You have either:

- 3a. Started this working day, or
- 3b. Finished last working day, or
- 3c. Finished last working day and started this working day,

with no driver card inserted.

(▷ User scenario 3: New working day with previous activities, page 33).



- Manual entries can be made only when the vehicle is stationary.
- It is possible to enter up to 16 activities.
- Manual entry procedure will end and save the recently completed entries if you:
 - Don't interact with the VU for 1 minute.
 - Begin driving the vehicle.
 - Insert or withdraw a driver card in the other slot.
 - Press and hold the button (cancel).

In case manual entries are needed

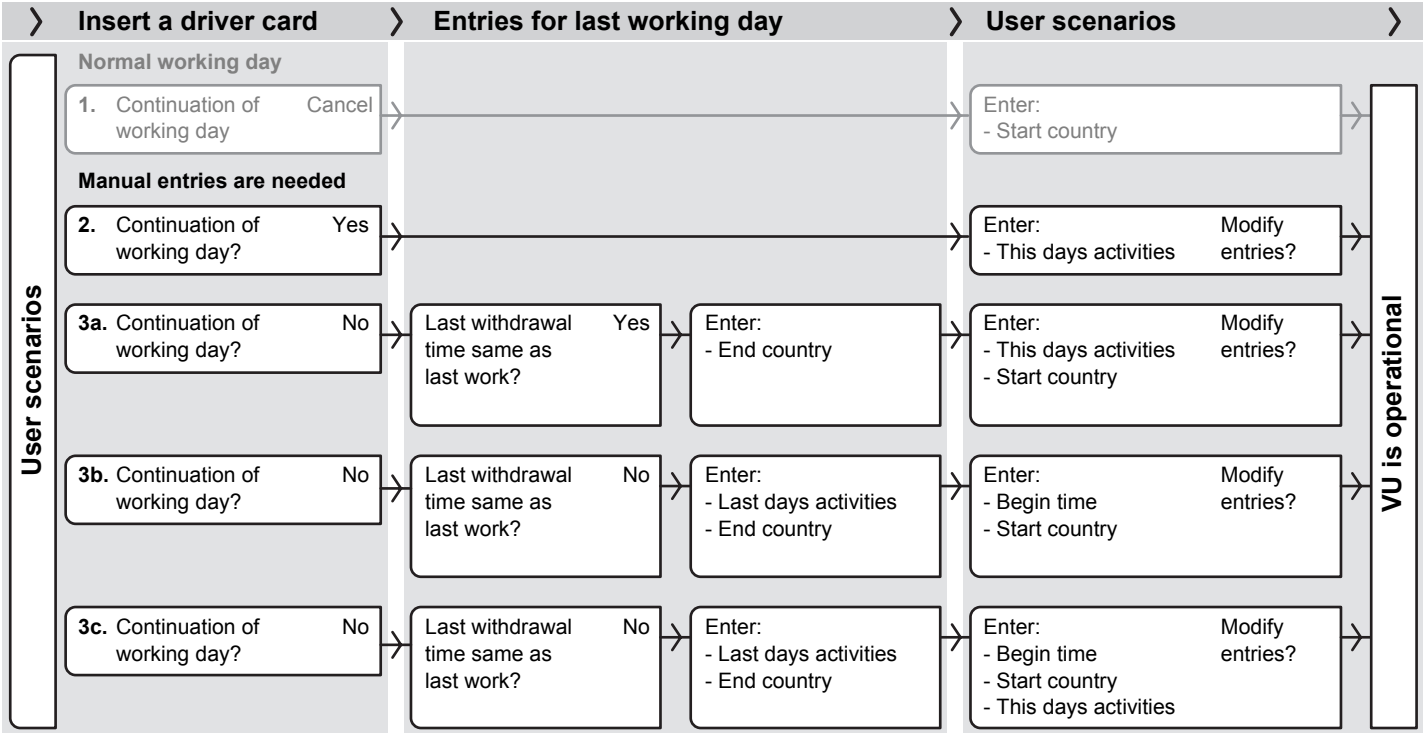

N54.61-2134-31

In case manual entries are needed

User scenario 2: Continuing present working day

You are continuing the present working day, but you have for a period worked with no driver card inserted.



It is possible to enter up to a maximum of 16 activities.

▶ (▷ Initial displays and entries, page 24)

▶ Continuing present working day?
Select ✓ (yes) using the or button and press the button.

```
▶?▶Cont. day.? ✓
15:23 08.07.2005 ✕
```

▶ Enter all activities carried out today after this days last withdrawal of driver card until it was inserted again.

(▷ Enter activity type and times, page 40)

```
1 H 0 + 01M
16:15 08.07.2005
```

▶ Returning here from “Enter activities manually”.

▶ Confirm the entries by selecting ✕ (not modify) using the or button and press the button.

```
Modify ✓
Entries? ✕
```

The following message appears:

```
Saving
activities 8
```

The VU is now operational and you will see the standard display.

(▷ VU standard display, page 16).

In case manual entries are needed

User scenario 3: New working day with previous activities

This is a new working day with previous activities. You have done either of following:

- 3a.** You have started this working day with no driver card inserted.
(▷ 3a. Started this working day with no driver card inserted, page 34).

- 3b.** You have finished last working day with no driver card inserted.
(▷ 3b. Finished last working day with no driver card inserted, page 36).

- 3c.** You have finished last working day AND started this working day with no driver card inserted.
(▷ 3c. Finished last working day AND started this working day with no driver card inserted, page 38)

In case manual entries are needed

3a. Started this working day with no driver card inserted

This is a new working day with previous activities. You have started this working day with no driver card inserted.



It is possible to enter up to a maximum of 16 activities.

- ▶ (▷ Initial displays and entries, page 24)
- ▶ Continuing present working day?
Select ✗ (no) using the or button and press the button.

```

▶?▶Cont. day.? ✓
15:23 08.07.2005 ✗
    
```

- ▶ Last card withdrawal time same as end of last work?
Select ✓ (yes) using the or button and press the button.

```

▶?Last work? ✓
15:23 08.07.2005 ✗
    
```

- ▶ Enter country at end time of the last working day.

```

▶*Select country
European Com.
    
```

- ▶ Enter all activities carried out today from the beginning of this working day up to insertion time of driver card
(▷ Enter activity type and times, page 40)

```

1h 0+ 01M
09:18 09.07.2005
    
```

- ▶ Returning here from “Enter activities manually”.
- ▶ Do you need to modify the entries?
(▷ Modify manual entries, page 45)
- ▶ Confirm the entries by selecting ✗ (not modify) using the or button and press the button.

```

Modify ✓
Entries? ✗
    
```

The following message appears:

```

Saving
activities ✗
    
```

In case manual entries are needed

- ▶ Enter country at beginning time of this working day.

```
• MSelect country
European Com.
```

The VU is now operational and you will see the standard display.

(▷ VU standard display, page 16).

In case manual entries are needed

3b. Finished last working day with no driver card inserted

This is a new working day with previous activities. You have finished last working day with no driver card inserted.

Enter the activities in two steps

The entering procedure is divided into two steps:

- Step 1 - Last working day:
Activities carried out after driver card withdrawal up to the finish of last working day.
- Step 2 - This working day:
Start time of present working day.



It is possible to enter up to a maximum of 16 activities.

Step 1 - Last working day

- ▶ (▷ Initial displays and entries, page 24)
- ▶ Continuing present working day?
Select ✕ (no) using the or button and press the button.

```
▶?MCont. day.? ✓
15:23 08.07.2005 ✕
```

- ▶ Last card withdrawal time same as end of last work?
Select ✕ (no) using the or button and press the button.

```
M?Last work? ✓
15:23 08.07.2005 ✕
```

- ▶ Enter all activities carried out after last days driver card withdrawal up to the finish of last working day.
(▷ Enter activity type and times, page 40).

```
1H0+ 01M
16:15 08.07.2005
```

- ▶ Returning here from “Enter activities manually”.
- ▶ Enter country at end time of last working day.

```
M*Select country
European Com.
```

In case manual entries are needed

Step 2- This working day

- ▶ The VU by default uses the end time of the last days last entry as the time when this working day started.

```

@ ▶?Begin time?
19:24          08.07.2005
  
```

- ▶ Change the time so that it equals the driver card insertion time.
- ▶ Press the or button, followed by pressing the button to set the year and month respectively, if necessary.
- ▶ Press the or button, followed by pressing the button to set the day and time respectively.
- ▶ Enter country at beginning time of this working day.

```

* ▶Select country
European Com.
  
```

- ▶ Do you need to modify the entries?
(▷ Modify manual entries, page 45)
- ▶ Confirm the entries by selecting ✕ (no more modification) using the or button and press the button.

```

Modify          ✓
Entries?       ✕
  
```

The following message appears:

```

Saving
activities     ⌘
  
```

The VU is now operational and you will see the standard display.

(▷ VU standard display, page 16).

In case manual entries are needed

3c. Finished last working day AND started this working day with no driver card inserted

This is a new working day with previous activities. You have both finished last working day AND started this working day with no driver card inserted.

Enter the activities in two steps

The entering procedure is divided into two steps:

- Step 1 - Last working day:
Activities carried out after driver card withdrawal up to the finish of last working day.
- Step 2 - This working day:
Activities carried out from the beginning of this working day up to insertion time of driver card.



It is possible to enter up to a maximum of 16 activities.

Step 1 - Last working day

- ▶ (▷) Initial displays and entries, page 24
- ▶ Continuing present working day?
Select ✘ (no) using the or button and press the button.

```

▶?MCont. day.? ✓
15:23 08.07.2005 ✘
    
```

- ▶ Last card withdrawal time same as end of last work?
Select ✘ (no) using the or button and press the button.

```

M?Last work? ✓
15:23 08.07.2005 ✘
    
```

- ▶ Enter all activities carried out after last days driver card withdrawal up to the finish of last working day.
(▷ Enter activity type and times, page 40).

```

1H0+ 01M
16:15 08.07.2005
    
```

- ▶ Returning here from “Enter activities manually”.
- ▶ Enter country at end time of last working day.

```

M*Select country
European Com.
    
```

A new working day is created.

In case manual entries are needed

Step 2- This working day

- ▶ The VU by default uses the end time of the last days last entry as the time when this working day started.

```

* ▶?Begin time?
19:24      08.07.2005
  
```

- ▶ Change the time so that it equals this days first activity's start time.
- ▶ Press the or button, followed by pressing the button to set the year and month respectively, if necessary.
- ▶ Press the or button, followed by pressing the button to set the day and time respectively.
- ▶ Enter country at beginning time of this working day.

```

* ▶Select country
European Com.
  
```

- ▶ Enter all activities carried out from the beginning of this working day up to insertion time of driver card.
(▷ Enter activity type and times, page 40)

```

1 h 0 +      01M
09:18      09.07.2005
  
```

- ▶ Returning here from "Enter activities manually".
- ▶ Do you need to modify the entries?
(▷ Modify manual entries, page 45)
- ▶ Confirm the entries by selecting (no more modification) using the or button and press the button.

```

Modify      ✓
Entries?    ✗
  
```

The following message appears:

```

Saving
activities  ✗
  
```

The VU is now operational and you will see the standard display.

(▷ VU standard display, page 16).

In case manual entries are needed

Enter activity type and times

A working day is defined by the activities carried out by driver 1 and driver 2.

Manual entries are needed in case a change of activity has not been entered at the time of the change. The activity then has to be entered manually at next insertion of driver card.

Each activity has to be defined by:

- Type of activity
- Activity start time.
- Activity end time.



- It is possible to enter up to 16 activities.
- To return to the previous entry press the button.

Limitations for entering of time

There are limitations for the entering of time to define a working day and its activities:

Working day start/end times:

- start time can't be set earlier than the time of the last driver card withdrawal
- end time can't be set later than the time for the last driver card insertion.

Activities start/end time can be entered:

- for up to 24 hours after last withdrawal of driver card
- for up to 24 hours before recent insertion of driver card.

Time periods for adjacent activities may not overlap in time.

In case manual entries are needed

Activity type and start time

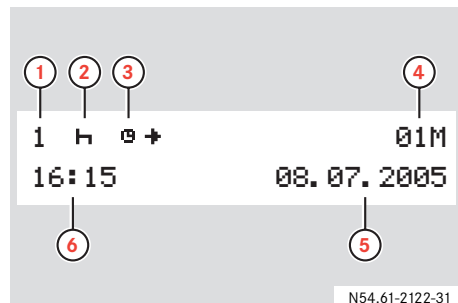

- 1 Driver
- 2 Type of activity
- 3 Start of the activity
- 4 Counter of manually entered activities
- 5 Date
- 6 UTC time at which the activity started



During the time entering procedure the local start time (🕒) is shown in the upper row simultaneously with the UTC time in the lower row.



The activity start time initially defaults to the last driver card withdrawal time.

1 🕒 + 01M
16:15 08. 07. 2005

- ▶ The counter of manually entered activities initially defaults **01M**. The counter will then increment **02M, 03M** for each manually entered activity.
- ▶ Press the or button to select type of activity.
(▷ Working day activities, page 18)
- ▶ Press the button.
- ▶ Press the or button, followed by pressing the button to set the year and month respectively, if necessary.
- ▶ Press the or button, followed by pressing the button to set the day and time respectively.

- ▶ After the time has been entered, the display moves on to enable you to enter the end of the activity.

(▷ Activity end time, page 42)

Activity end time

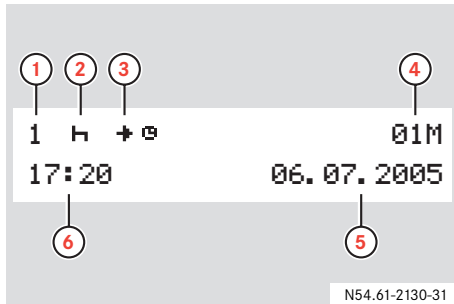

- 1 Driver
- 2 Type of activity
- 3 End of the activity
- 4 Counter of manually entered activities
- 5 Date
- 6 UTC time at which the activity ended



During the time entering procedure, the local end time (+ 0) is shown in the upper row simultaneously with the UTC time in the lower row.



The activity end time initially defaults to:

- This days card insertion time, if the activity end time occurred this working day.
- Last days card withdrawal time, if the activity end time occurred last working day.

1 H + 0 01M
17:20 06. 07. 2005

- ▶ Press the or button, followed by pressing the button to set the year and month respectively, if necessary.
- ▶ Press the or button, followed by pressing the button to set the day and time respectively.

Last day's activities end time

- ▶ For last working day's manually entered activities, enter end time for each activity until the last activity end time equal card withdrawal time.

W?Last work?	✓
15:23 08. 07. 2005	✗

- ▶ Select ✗ (no) until all activities have been entered, then select ✓ (yes) using the or button and press the button.
- ▶ Return to the appropriate user scenario, at "Returning here from...":
 - (▷ 3b. Finished last working day with no driver card inserted, page 36)
 - (▷ 3c. Finished last working day AND started this working day with no driver card inserted, page 38)

In case manual entries are needed

This day's activities end time

- ▶ For this working day's manually entered activities, enter beginning time for each activity until:
 - all activities have been entered, and
 - the last activity end time equals the driver card insertion time.

```

07:24 09.07.2005
  
```

- ▶ Press the or button, followed by pressing the button to set the month, day and begin time respectively.
- ▶ Return to the appropriate user scenario, at "Returning here from...":

(▷ User scenario 2: Continuing present working day, page 32)

(▷ 3a. Started this working day with no driver card inserted, page 34)

(▷ 3c. Finished last working day AND started this working day with no driver card inserted, page 38)

In case manual entries are needed

Enter the country

You must specify where the vehicle was/is during a working day. You can do this:

- Whenever during a working day using main menu item **Begin Place** or **End Place**.
- When automatically prompted at each insertion and withdrawal of a driver card (▷ Initial displays and entries, page 24).
- During manual entries of activities (▷ Manual entries overview, page 30).



Manual entries can be made only when the vehicle is stationary.

Whenever during a working day

- ▶ Press the button to show the main menu and press the or button to select menu **Begin Place** or **End Place**.



- ▶ Press the button.
- ▶ Press the button again.

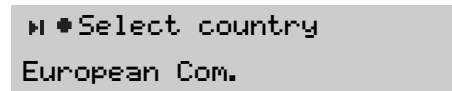

You will find a list of all countries available in the VU in the appendix

(▷ Available countries, page 99).

- ▶ Press the or button to select the country and press the button.



For Spain, it is also necessary to select the region.

(▷ Spanish regions, page 100)

In case manual entries are needed

Modify manual entries

You can modify manual entries as follows:

- Change activities
- Add activities
- Delete activities



You can not modify your manual entries after:

- They have been confirmed. (▷ Save the entries, page 46).
- You have exit the modify entries mode (▷ There are several ways to exit the manual entries mode without completing the entries:, page 47).
- You have begun driving.

► Modify entries?

Select ✓ using the or button and press the button.

Modify	✓
Entries?	✗

► Press the button. The activities counter is highlighted.

► Press the or button to scroll through the activities entered.

Change activities

► Press the button to select the activity.

► Activities are changed in the same way as they initially are entered (▷ Enter activity type and times, page 40).

► Press the button to move along to the activities counter.

► Press the button to go back to **Modify entries?**.

Move backwards in present entry



► Press the button repeatedly

In case manual entries are needed

Add activities

- ▶ Press and hold .

```
M Add or      +
delete entry  -
```

- ▶ Select + using the  or  button and press the .







The new activity will be inserted before the selected entry.

- ▶ Enter the activity
(▷ Enter activity type and times, page 40).
- ▶ Press the  button to go back to **Modify entries?**.

Delete activities

- ▶ Press and hold .

```
M Add or      +
delete entry  -
```

- ▶ Select - using the  or  button and press .
- ▶ Press the  button to go back to **Modify entries?**

(▷ [Modify manual entries, page 45](#)).

Save the entries

- ▶ Select  and press the  button.

The following message appears:

```
          Saving
          activities  X
```

The VU is now operational and you will see the standard display

(▷ [VU standard display, page 16](#)).

In case manual entries are needed

Exit manual entries mode

There are several ways to exit the manual entries mode without completing the entries:

- Begin driving.
- Insert or withdraw a driver card.
- Do not interact with the VU for 1 minute.
- Accept the VU default times, based on last driver card withdrawal and insertion times.
- Cancel modify mode by pressing and holding the **X** button.



If you exit the modify entries mode without completing the entries, the manual entries you have made will be saved.

The VU will be operational and you will see the standard display

(▷ VU standard display, page 16).

Accept the default times

- ▶ Press the **←** button to move along through the default start and end time of the activity.
- ▶ Save the modified entries?
Select **X** and press the **←** button.

```
Modify ✓
Entries? X
```

The following message appears:

```
Saving
activities X
```

The VU is now operational and you will see the standard display

(▷ VU standard display, page 16).

Cancel modify mode

- ▶ Press and hold the **X** button.

The entries are saved and the following message appears:

```
Saving
activities X
```

The VU is now operational and you will see the standard display

(▷ VU standard display, page 16).

Journey with ferry or train

Enter before journey

To register activity during a ferry or a train journey the ferry/train mode must be manually activated before the journey begins.



- Activation is only possible when the vehicle is stationary.
- When on board a ferry or a train the vehicle does not move and the speed sensor thereby cannot record any activity.

Activate ferry/train mode

- ▶ Show the main menu display by pressing the button.
(▷ VU main menu display, page 17)
- ▶ If not already shown, select menu **OUT** using the or button.



- ▶ Press the button.
- ▶ Select activity using the or button.

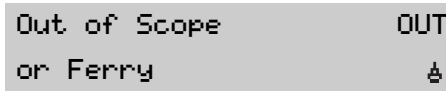

- ▶ Press the button.
Ferry/train mode is activated. This can be seen only at the standard display.
- ▶ Press the button to return to the standard display. The ferry/train symbol is in the position for activity.
(▷ VU standard display, page 16)

Deactivate ferry/train mode

The ferry/train mode cannot be manually deactivated. However it will be automatically deactivated when you do either of:

- Start driving.
- Activate Out of scope mode.

When the Ferry/train mode is deactivated the ferry/train symbol is no longer in the position for activity at the standard display. (▷ VU standard display, page 16).

Journey where no recording is required

Driving out of scope

If you are using the vehicle in conditions where the EU tachograph regulation 3820/85 does not apply, then recording of these activities is not required. This situation is called to drive “Out of scope”.

Out of scope driving could be, for example:

- Driving a vehicle that is only partly loaded in respect of weight, so that the vehicle gross weight does not exceed the limit at which a tachograph is required.
- Driving in a country outside EU.
- Driving on a non public road, for example driving in a gravel pit or off road.



Drivers are responsible for ensuring that they obey driving laws in respective country.

Activate out of scope mode

- ▶ Show the main menu display by pressing the button.
(▷ VU main menu display, page 17)
- ▶ If not already shown, select menu **OUT** using the or button.

OUT /	
OUT of scope	

- ▶ Press the button.
- ▶ Select activity **OUT** using the or button.

Out of Scope	OUT
or Ferry	

- ▶ Press the button.
Out of scope mode is activated. This can be seen only at the standard display.

- ▶ Press the button to return to the standard display. The Out of scope symbol **OUT** is in the position for activity.
(▷ VU standard display, page 16)



Journey where no recording is required

Deactivate out of scope mode

To deactivate Out of scope mode:



- Automatically:
withdraw or insert a driver card.
- Manually enter end of Out of scope mode.

Manually enter end of out of scope mode

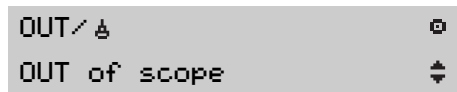

- ▶ Show the main menu display by pressing the  button.
(▷ VU main menu display, page 17)
- ▶ If not already shown, select menu **OUT** using the  or  button.



- ▶ Press the  button.

- ▶ Select ✓ using the  or  button to end out of scope (ferry/train).



- ▶ Press the  button.
Out of scope mode is deactivated.
This can be seen only at the standard display.
- ▶ Press the  button to return to the standard display. The Out of scope symbol **OUT** is no longer in the position for activity.

(▷ VU standard display, page 16)

Printouts

Create a printout

It is possible to create different printouts of VU and driver card data.



- The data can also be shown on the display.
- It is only possible to print out when the vehicle is stationary.
- It is possible to print out data from up to 8 days ago for the driver card inserted.



Keep the slot on the paper cassette unobstructed, otherwise there is a risk of a paper jam in the printer.

- ▶ Press the button.
- ▶ Press the or button until **Print menu** appears in the display.

```

▼ / □ Print
Menu
  
```

- ▶ Press the button. The first print menu item is shown on the display.

```

24h □ ▼ Print
24h card
  
```

- ▶ Press the or button to select the type of print out (▷ Types of printout, page 53).



There is a sub menu, **Additional Print menu**, that contains another three types of printouts.

- ▶ Press the button.

Depending on the type of print out, it may also be necessary to select the driver card and the date:

- ▶ Press the or button to select the driver card inserted in the slot for driver 1 or driver 2.

```

Select card      1
1 or 2          2
  
```

- ▶ Press the button.
- ▶ Press the or button to select the day for the desired date.

```



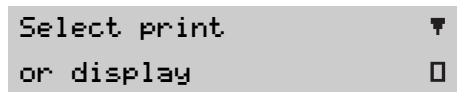

Enter Date
  
```

Printouts

- ▶ Press the  button.
- ▶ Choose where to show the printout.



Printing out data



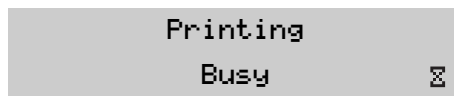



- ▶ Select  using the  or  button.
- ▶ Press the  button to print out the data.



You can cancel the ongoing printing process using the  button.























- ▶ As soon as the **Printing busy** message is cleared:
pull the printout upwards and tear it off.

Displaying data on the display

- ▶ Select  using the  or  button.
- ▶ Press the  button to display the data.
- ▶ Press the  or  button to scroll through the data.

Printouts

Types of printout

Display message	Type of printout	Description
24h   Print 24h card	 Daily activities from the driver card 	List of all activities stored on a driver card for the selected day.
24h   Print 24h VU	 Daily activities from the VU 	List of all activities stored in the VU for the selected day.
!X   Print event card	 Warnings from the driver card 	List of all events and malfunctions stored on a driver's driver card.
!X   Print event VU	 Warnings from the VU 	List of all events and malfunctions stored in the VU.
T   Print technical data	 Technical data 	List of the technical data in a VU.
>>  Print overspeeding	 Data on overspeeding 	List of all overspeeding events.

Printouts

Display message	Type of printout	Description
▼/□ Additional print menu	⊙ ⬆	Additional print sub menu Sub menu for another three print menu items.
RPM ▼ Print engine speed	⊙ ⬆	Additional print sub menu: Engine speed (rpm) List of engine speed bands in rpm.
D1/D2 ▼ Print status D1/D2	⊙ ⬆	Additional print sub menu: Status driver D1/D2 List of changes in status for driver 1 and driver 2.
Km/h ▼ Print vehicle speed	⊙ ⬆	Additional print sub menu: Vehicle speed (km/h) List of vehicle speed bands in km/h.

Printouts

Printouts at a glance

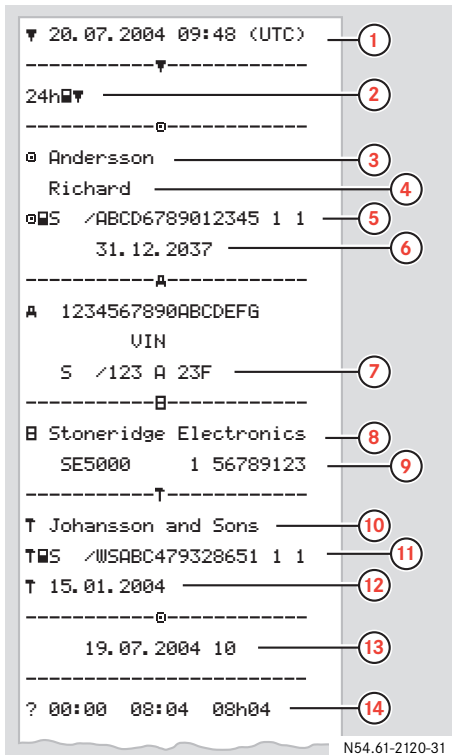

Meaning	
1	Date and time (UTC)
2	Type of printout
3	Card holder's surname
4	Card holder's first name
5	State in which the card was issued
6	Date of validity of the driver card
7	Country and official registration number of the vehicle
8	Tachograph manufacturer
9	VU part number
10	Workshop responsible for last calibration
11	Workshop card number
12	Date of last calibration
13	Date of printed activities. Counter of how many times the card has been inserted in a VU this date.
14	Period of unknown activity

(Continuing on next page) >>



* 17:33	18:26	00h53		15
-----1-----				16
#5	/123	A 23F		17
	97	206 km		18
08:04	11:00	02h56		19
H 11:00	14:39	03h39	*	
0 14:39	15:32	00h53		
0 15:32	15:53	00h53		
H 15:53	17:10	01h17	*	
0 17:10	17:15	00h05		
H 17:15	17:29	00h14		
0 17:29	17:33	00h04		20
	97	716 km	510 km	

N54.61-2121-31

Meaning

15	Manually entered activity
16	Driver card in slot 1
17	Licence number of the vehicle driven with this driver card
18	Total distance at driver card insertion time
19	Activities with driver card inserted
20	Total distance and trip distance at card withdrawal time

Settings

You can change these settings:

- UTC time +/- 1 minute per week
- Local time
- Display appearance



It is only possible to change settings when the vehicle is stationary.

UTC time

All activities are recorded by the VU using UTC time (Universal Time Coordinated):

- UTC time is more or less corresponds to Greenwich Mean Time (GMT).
- It is a time measurement that is based on the number of seconds elapsed since 1st January 1970.
- The UTC time is not adjusted for summer/winter time.

Change the UTC time



- The UTC time may deviate by ± 1 minute per week in the VU. It can therefore be corrected by ± 1 minute once a week.
- The UTC time cannot be set closer to the card expiry date than one hour.
- If the UTC time in the VU has deviated by more than 20 minutes, the VU must be recalibrated by a specialist workshop for tachographs.

- ▶ Press the button.
- ▶ Press the or button until **Setting menu** appears in the display.
- ▶ Press the button.
- ▶ Press the or button until **Settings UTC** appears in the display.
- ▶ Press the button.

- ▶ Press the or button to adjust the UTC time by 1 minute.

UTC	26.05.2005
10:	38

- ▶ Press the button to confirm.

Settings

Local time

Current time in the country in which you and the vehicle are currently present.

Change the local time



The local time can be adjusted in increments of 30 minutes.

- ▶ Press the button.
- ▶ Press the or button until **Setting menu** appears in the display.
- ▶ Press the button.
- ▶ Press the or button until **Settings local time** appears in the display.
- ▶ Press the button.

- ▶ Press the or button to set the local time.

Local Time

09:40



- ▶ Press the button to confirm.

Display appearance

The display can be set in either of following appearance modes:



- Positive view
- Negative (inverted) view.

Change the view

- ▶ Press the button.
- ▶ Press the or button until **Setting menu** appears in the display.
- ▶ Press the button.
- ▶ Press the or button until **Settings Invert display** appears in the display.
- ▶ Press the button.



Settings

Select a positive view

- ▶ Select + using the  or  button and press the  button.

```
Invert display +  
-
```

Select a negative (inverted) view

- ▶ Select - using the  or  button and press the  button.

```
Invert display +  
-
```

Displays

Messages

Warnings

Malfunctions

Displays when in motion

You can choose either of these five displays when the vehicle is in motion.

▶ Press the or button.

Display	Display type	Data displayed
	Standard display	<ul style="list-style-type: none"> • Activities of driver 1 and driver 2 • Activity duration • Cumulative break time of driver 1 in a working day • Local time • Mode of operation
	Speed display	<ul style="list-style-type: none"> • Activities of driver 1 and driver 2 • Odometer • Current speed • Local time
UTC 08:44 13. 10. 2005	UTC time display	<ul style="list-style-type: none"> • UTC time • Date
	Driving time and break time display	<ul style="list-style-type: none"> • Driving time of driver 1 and driver 2 • Cumulative break time of driver 1 and driver 2
	Cumulative driving time	<ul style="list-style-type: none"> • Cumulative driving time of driver 1 and driver 2 during the last 14 days, regardless of week day









Displays











Symbols







The symbols shown on the display and the printouts represent persons, activities or processes of the VU.

The symbols may also appear in combination (▷ Symbol combination meanings, page 65).

Symbol meanings

Symbol	Meaning
1, 	Driver 1
2, 	Driver 2
	Driver card
	Eject
	Work
	Driver/driving
	Rest
	Availability

Symbol	Meaning
?	Question/unknown
	Break
	Time
	Ferry/train journey
OUT	Monitoring equipment not required
	Manually entered activity
	Location
	Start of work
	End of work
	From or to
	Printout
	Paper
	Display

















Symbol	Meaning
24h	Daily
	Weekly
	Two weeks
Σ	Cumulative.../summary
	Speed
	Processing, please wait
	Message, warning or malfunction
!	Message, warning or malfunction
	Vehicle, VU
	Tyre size
Π	Sensor
	Power supply



Displays











Symbol	Meaning
†	Workshop / test centre
♁	Company
♁	Inspector
♁	Manufacturer
∠	Housing open
♁	Security
‡	External storage
‡	Lock

Displays

Symbol combination meanings

Combina- tion	Meaning
 ? 	Same working day?
 ?	End of work of previous working day?
  ?	Enter country in which work started
 	Country in which work started
  ?	Enter country in which work ended
 	Country in which work ended
 +	Start time (UTC time)
 	Start time (local time)
+ 	End time (UTC time)
 	End time (local time)

Combina- tion	Meaning
+ OUT	End of “Monitoring equipment not required”
OUT +	Start of “Monitoring equipment not required”
	Driving time for one week
	Driving time for two weeks
↓ °	Low temperature
↑ °	High temperature

Combina- tion	Meaning
 ---	No card
 	Driver card
 	Workshop card
 	Company card
 	Control card
 +	Control location
 +	Data from the VU

Messages, warnings and malfunctions

The information displayed on the VU is separated into three types of events, depending on the seriousness a specific occurrence:

- messages
- warnings
- malfunctions

An alphabetical list of all driver messages, warnings and malfunctions is presented on the following pages.

In this list “Driver Card” is shortened and is named “Card”.

Messages

Messages inform you of completed processes, problems with your driver card or remind you to take a break, for example.

Messages are not stored.

Clear a message:

- ▶ Press the  button.

Warnings

Warnings appear in the event of law infringements, such as overspeeding, or if VU data cannot be recorded for various reasons.

Warnings either pop up or flash at the display.

Warnings are stored and can be printed out on paper or to the display.

(▷ Create a printout, page 51)

Clear a warning:

Press the  button twice.

Messages, warnings and malfunctions

Malfunctions

Malfunctions are more critical than warnings. They are displayed in case of VU, sensor or driver card faults or if tampering with this equipment is detected.

Malfunctions are stored and can be printed out on paper or to the display.

(▷ Create a printout, page 51)

Acknowledge a malfunction:

Press the  button.

Display	Type	Unit	Description	Action
✘ 1 Card 1 fault	Mal-function	Card	The driver card in slot 1 (“2” if slot 2) is defective.	<ul style="list-style-type: none"> ▶ Eject card and check visually. ▶ Clean with a soft damp cloth and try again. ▶ If the display still is shown, perform a self test (▷ page 83).
! 1 Card 1 time overlap	Warning	VU	The time at which the inserted driver card in slot 1 (“2” if slot 2) was last withdrawn is later than the UTC time in the VU.	<ul style="list-style-type: none"> ▶ Check the UTC time of the VU and adjust it if necessary (▷ page 57). ▶ If the UTC time in the VU has deviated by more than 20 minutes, take the tachograph to a tachograph workshop for recalibration.
! 2 Card auth. failure	Mal-function	Card	The VU security check for the driver card in slot 2 (“1” if slot 1) failed.	<ul style="list-style-type: none"> ▶ Eject card and check visually. ▶ Clean with a soft damp cloth and try again. ▶ If the display still is shown, perform a self test (▷ page 83).
! Card conflict	Warning	Card	Different card types have been inserted in the slots at the same time (e.g. workshop and driver card).	<ul style="list-style-type: none"> ▶ Withdraw one of the cards.

Messages, warnings and malfunctions

Display	Type	Unit	Description	Action
! Ⓜ ← Ⓜ 2 Card data integrity error	Mal-function	VU	Corrupt data detected when reading data from the driver card in slot 2 (“1” if slot 1) to the VU.	<ul style="list-style-type: none"> ▶ Eject card and check visually. ▶ Clean with a soft damp cloth and try again. ▶ If the fault remains, perform a self test (▷ page 83).
! Ⓜ → * 2 Card eject without saving	Message	Card	Data could not be stored on the driver card withdrawn from slot 2 (“1” if slot 1) due to an error.	<ul style="list-style-type: none"> ▶ Eject card and check visually. ▶ Clean with a soft damp cloth and try again. ▶ If the display still is shown, perform a self test (▷ page 83).
Ⓜ Ⓜ 1 Card expired	Message	Card	The driver card inserted in slot 1 (“2” if slot 2) has expired.	<ul style="list-style-type: none"> ▶ Remove the driver card and replace it with a valid one.
! Ⓜ Ⓜ Card ins. while driving	Warning	Card	A driver card was inserted while the vehicle was in motion.	<ul style="list-style-type: none"> ▶ Continue the journey if the driver card is valid.
! Ⓜ A/A Data integrity error	Mal-function	VU	The user data stored in the VU has errors.	<ul style="list-style-type: none"> ▶ Visit a specialist workshop for tachographs to have the equipment checked.

Display	Type	Unit	Description	Action
⊙ [] / [] * Driving can't open slot	Message	VU	An attempt was made to open the slot while the vehicle was in motion.	▶ Stop the vehicle. The driver card slot can be opened only when the vehicle is stationary.
! ⊙ [] Driving w/o valid card	Warning	Card	The vehicle has pulled away even though there is no driver card in slot 1.	▶ Stop the vehicle at the earliest opportunity and insert a valid driver card.
fn* Function not possible	Message	VU	The desired function cannot be carried out.	- - -
! [] A Hardware sabotage	Mal-function	VU	Unpermitted modifications have been carried out on the VU.	▶ Visit a specialist workshop for tachographs to have the equipment checked.
! [] Insertion of a non valid card	Warning	Card	Driver card is: <ul style="list-style-type: none"> • non valid • expired • defective or dirty or in other means incorrect.	▶ Eject card and check visually. ▶ Clean with a soft damp cloth and try again. ▶ Insert a valid driver card. ▶ If the display still is shown, perform a self test (▷ page 83).
! [] A → A Int. data transfer error	Mal-function	VU	There was an error in the transfer of internal data to the VU.	▶ Visit a specialist workshop for tachographs to have the equipment checked.

Messages, warnings and malfunctions

Display	Type	Unit	Description	Action
>24h ■ + Last card withdrawal >24h.	Message	Card	The driver card inserted was last withdrawn from the VU more than 24 hours ago.	▶ The VU automatically creates a new working day.
! ■ A2 Last sess. not closed ok	Warning	Card	<ul style="list-style-type: none"> • The driver card in slot 2 (“1” if slot 1) was ejected incorrectly during the last session. • The previous card withdrawal in slot 2 (“1” if slot 1) was not completed correctly by the VU. 	<ul style="list-style-type: none"> ▶ Eject card and check visually. ▶ Clean with a soft damp cloth and try again. ▶ If the display still is shown, perform a self test (▷ page 83).
M.....! Memory full!	Message	VU	Manual entries memory full.	▶ Modify the manual entries so that the total number of entries is less.
! @ / T ■ No driver/workshop card	Message	Card	A function has been selected that requires an inserted driver or workshop card.	<ul style="list-style-type: none"> ▶ Insert a driver card. ▶ Visit a specialist workshop for tachographs to have the equipment checked.
! ■ !? No further details	Malfunction	Sensor	An unknown type of sensor error occurred.	▶ Visit a specialist workshop for tachographs to have the equipment checked.

Display	Type	Unit	Description	Action
>> Over speeding	Warning	---	The vehicle speed has for 1 minute exceeded the over speed limit set and will be stored.	▶ Observe the specified speed limit.
>> Overspeeding pre-warning	Message	---	<ul style="list-style-type: none"> • The current speed of the vehicle is exceeding the over speed limit set. • After 1 minute of continuous over speeding the event will be stored. 	▶ Observe the specified speed limit.
! † Power supply interruption	Warning	VU	The VU supply voltage is below the minimum limit or above the maximum limit for the correct operation of the VU.	▶ Visit a specialist workshop for tachographs if the reason for the message is unknown.
▼ ↑ ◦ Printer high temperature	Message	Printer	The printing could not start because the temperature of the printer is out of allowed range.	<p>▶ Lower the temperature in the vehicle interior.</p> <p>▶ If the printer still fails, visit a specialist workshop for tachographs to have the equipment checked.</p>

Messages, warnings and malfunctions

Display	Type	Unit	Description	Action
Printer high temperature	Message	Printer	The ongoing printing has been interrupted because the temperature of the printer is out of allowed range.	<ul style="list-style-type: none"> ▶ Lower the temperature in the vehicle interior. ▶ If the printer still fails, visit a specialist workshop for tachographs to have the equipment checked.
Printer low power	Message	Printer	The ongoing printing has been interrupted because the VU input voltage is too low	<ul style="list-style-type: none"> ▶ Check the vehicle battery voltage, wiring, etc. ▶ If the printer still fails, visit a specialist workshop for tachographs to have the equipment checked.
Printer low temperature	Message	Printer	The printing could not start because the temperature of the printer is out of allowed range.	<ul style="list-style-type: none"> ▶ Lower the temperature in the vehicle interior. ▶ If the printer still fails, visit a specialist workshop for tachographs to have the equipment checked.
Printer out of paper	Message	Printer	The ongoing printing has been interrupted because the printer is out of paper.	<ul style="list-style-type: none"> ▶ Replace paper. ▶ If the printer still fails, visit a specialist workshop for tachographs to have the equipment checked.
Printing cancelled	Message	Printer	The ongoing printing has been cancelled.	- - -

Display	Type	Unit	Description	Action
>4 1/2h? Quarter left reminder	Message	- - -	The driver has 15 minutes left until the legally maximized continuous driving time of 4½ hours will be exceeded.	► Find a suitable place to take a break in the next 15 minutes.
! Ⓜ A * Security violation	Mal- function	- - -	Security breach attempt.	► Visit a specialist workshop for tachographs to have the equipment checked.
! Ⓜ Ⓜ Sensor auth. failure	Mal- function	Sensor	The VU does not detect the motion sensor.	► Visit a specialist workshop for tachographs to have the equipment checked.
! Ⓜ Ⓜ A Sensor auth. failure	Mal- function	Sensor	The VU does not recognise the connected motion sensor as the one installed.	► Visit a specialist workshop for tachographs to have the equipment checked.
! Ⓜ =0 Sensor cable fault	Warning	Sensor	Motion sensor data 0error.	► Visit a specialist workshop for tachographs to have the equipment checked.
! Ⓜ >0 Sensor cable fault	Warning	Sensor	Motion sensor data error.	► Visit a specialist workshop for tachographs to have the equipment checked.
x Ⓜ .. * Sensor comms error	Mal- function	Sensor	Motion sensor communication error.	► Visit a specialist workshop for tachographs to have the equipment checked.

Messages, warnings and malfunctions

Display	Type	Unit	Description	Action
! 0 Sensor data error	Warning	Sensor	There are errors in the motion sensor data.	► Visit a specialist workshop for tachographs to have the equipment checked.
! 0 0/0 Sensor data integrity error	Mal-function	Sensor	There are errors in the data in the motion sensor.	► Visit a specialist workshop for tachographs to have the equipment checked.
x 0 ✓ * Sensor no acknowledge	Mal-function	Sensor	Motion sensor communication error.	► Visit a specialist workshop for tachographs to have the equipment checked.
x 0 ← 0 * Sensor no answer	Mal-function	Sensor	Motion sensor communication error.	► Visit a specialist workshop for tachographs to have the equipment checked.
x A 0 † ↑ Sensor power high	Mal-function	Sensor	Sensor power to high.	► Visit a specialist workshop for tachographs to have the equipment checked.
x 0 † ↓ Sensor power low	Mal-function	Sensor	Sensor power to low.	► Visit a specialist workshop for tachographs to have the equipment checked.
! 0 † Sensor power no signal	Mal-function	Sensor	Sensor has no power.	► Visit a specialist workshop for tachographs to have the equipment checked.

Messages, warnings and malfunctions

Display	Type	Unit	Description	Action
A/T? Service prewarning	Message	VU	Next calibration, pre-warning	► Visit a specialist workshop for tachographs to have the equipment calibrated.
>4 1/2h Time for break reminder	Message	- - -	The legally maximized continuous driving time of 4½ hours has elapsed.	► Stop the vehicle at the earliest opportunity and take a break for 45 minutes.
☐ → ☐ Timeout no key pressed	Message	VU	The VU is waiting for input.	► Press the appropriate buttons and complete the process.
×☐/☐ ∠ * Unable to open slot	Message	VU	The slot concerned cannot be opened.	<ul style="list-style-type: none"> ► Check the slot for correct operation. ► If the slot still fails, visit a specialist workshop for tachographs to have the equipment checked.
!☐ ∟ ∟ Unauth. change of sensor	Mal- function	Sensor	The motion sensor connected is not approved for the VU.	► Visit a specialist workshop for tachographs to have the equipment checked.
!UTC Time adjust not allowed	Message	VU	UTC time adjustment more than +/- 1 minute once a week is not allowed.	► If the UTC time in the VU has deviated by more than 20 minutes, the VU must be recalibrated by a specialist workshop for tachographs.

Messages, warnings and malfunctions

Display	Type	Unit	Description	Action
xA UU internal error	Mal- function	VU	VU has detected an internal fault.	► Visit a specialist workshop for tachographs to have the equipment checked.
xA @ UU internal error	Mal- function	VU	VU has detected UTC validation failure.	► Visit a specialist workshop for tachographs to have the equipment checked.
xA UU Internal fault	Mal- function	VU	VU has detected an internal fault.	► Visit a specialist workshop for tachographs to have the equipment checked.

Maintenance and care

Changing the paper roll

Troubleshooting and self-test

Maintenance and care

Replacement parts for printer

Replacement part	Part no.
Paper roll	6800-001
Paper cassette	6800-002

Contact your local representative if you are in need of replacement parts.



Store the printer paper in a cool, dry and dark location.

Care for driver card



- Do not flex or bend.
- Ensure that the card contacts are kept free from dirt.
- Clean with a soft damp cloth if necessary.
- Protect from theft, loss or other damage.

Care for vehicle unit



- The ingress of dirt can lead to premature failure of the VU. Keep the slots closed at all times and only open them to insert and withdraw the driver cards.
- Clean a dirty VU with a damp, soft cloth.
- Do not place objects on the slot trays when they are open, otherwise the trays could be damaged.

Changing the paper roll

Remove the paper cassette

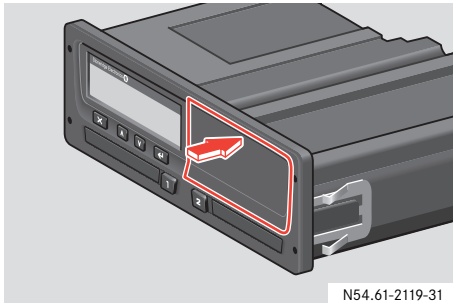

- ▶ Press the upper edge of the front panel.
The panel folds out.

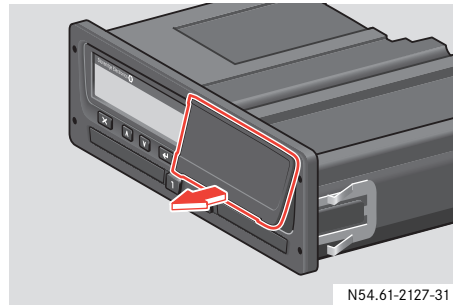

- ▶ Hold the panel by the lower edge.

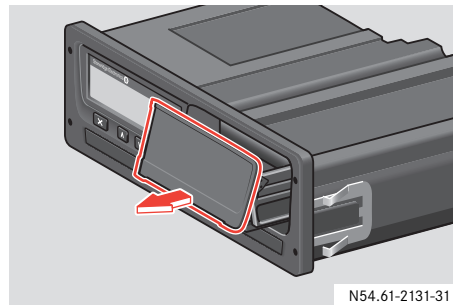

- ▶ Pull the paper cassette out carefully.

Changing the paper roll

Insert a paper roll



Only use printer paper approved by Stoneridge, otherwise there is a risk of printer malfunctions.

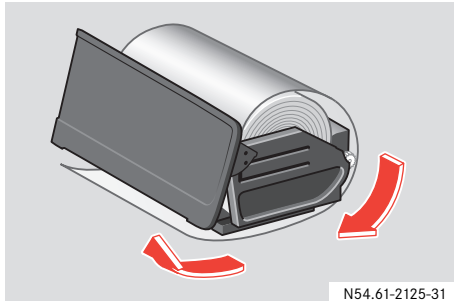

- ▶ Insert the paper roll and feed the paper around the back of the paper cassette and forwards towards the lower edge of the panel.

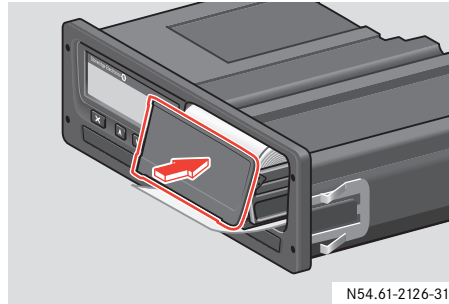

- ▶ Insert the paper cassette into the fixtures of the VU.
- ▶ Press the middle of the panel and slide the paper cassette into the VU until it engages.









Troubleshooting and self-test

The self-test can be used to check the following components of the VU for correct operation:

- Display
- Invert view function
- Printer
- Buttons
- Driver card

Self-test procedure

The self-test is only possible when the vehicle is stationary.

- ▶ Press the  button.
- ▶ Press the  or  button until **Setting menu** appears in the display.
- ▶ Press the  button.
- ▶ Press the  or  button until **Settings Built-In test** appears in the display.
- ▶ Press the  button.
- ▶ Press the  or  button to select a test.

Built-in test	□
⚙	⌘

See the table on the following pages for available tests.

Troubleshooting and self-test

▶ Press the  button.

Symbol	Test	Description	Action if test failed
□	Display	Display test The display is lit for 1 second and goes out for 1 second. A pattern of rows of lit and unlit segments is then displayed for 1 second.	▶ Visit a specialist workshop for tachographs to have the VU checked if the display is unreadable.
⌘	Invert view function	Invert view function test The display view is inverted for 2 seconds.	▶ Visit a specialist workshop for tachographs to have the VU checked if the display is unreadable.
⌵	Printer	Test page printed out	▶ Check the paper cassette and replace it if necessary. ▶ Visit a specialist workshop for tachographs to have the VU checked if the printer still does not work.

Troubleshooting and self-test

Symbol	Test	Description	Action if test failed
⌘	Buttons	<p>Button test</p> <p>You are prompted to press all buttons one after the other from left to right – each button must be pressed within 2 seconds of each other, otherwise the test fails.</p>	<ul style="list-style-type: none"> ▶ Carefully clean dirty buttons with a damp cloth and a mild detergent. ▶ Visit a specialist workshop for tachographs to have the VU checked if a button repeatedly fails to work.
■	Driver card	<p>Test of the inserted driver cards</p> <p>There must be a driver card in the relevant slot. The name of the card holder is read and displayed for 2 seconds.</p>	<ul style="list-style-type: none"> ▶ If a driver card is reported as defective, check a different driver card to ensure that it is not a fault with the VU. ▶ If the VU seems to be defective, visit a specialist workshop for tachographs to have the equipment checked. ▶ If it is the driver card that is definitely defective, contact the responsible authority in the country where your driver card was issued (▷ page 92).

Hazardous goods version / ADR

Data stored in vehicle unit and on driver card

Responsible authorities

Available countries

National importers

The ADR version of the VU is approved for use in hazardous goods vehicles. It differs from the standard VU in that it has explosion protection and it is certified in accordance with EU Directive 94/9EC.

Number for TÜV test certificate:
ATEX 2507 X,
with corresponding supplements.



The ADR VU explosion protection is only guaranteed when the vehicle is stationary and the battery isolating switch is open.

Special features of the ADR VU

The differences between the ADR VU and the standard VU are characterised by functions that are disabled when the ignition switched off:

- Inserted driver cards cannot be ejected.
- No printouts possible.

Background illumination for buttons and display off.

Hazardous goods version / ADR

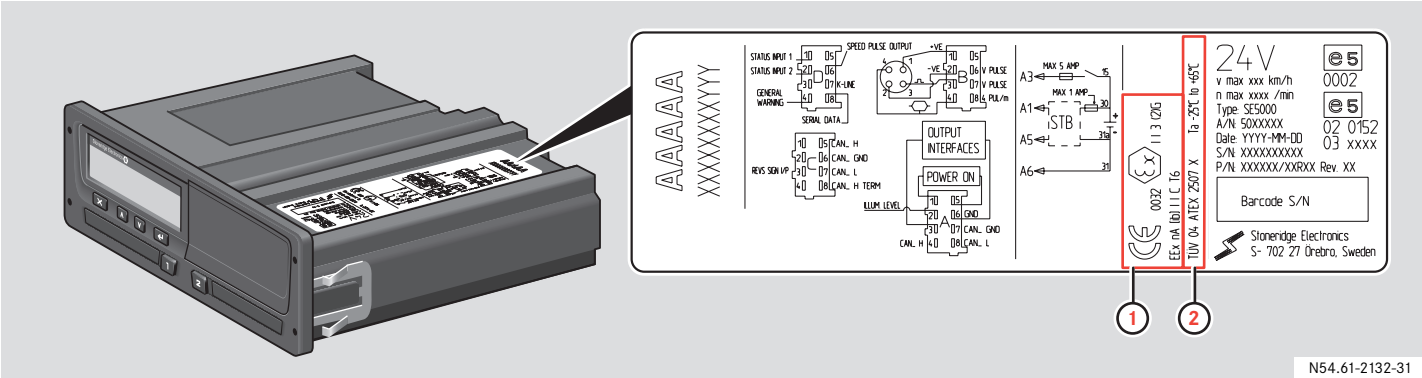

N54.61-2132-31

- 1 ADR symbol.
- 2 Number for TÜV test certificate.

Data stored on driver card and in vehicle unit

Various data is stored on driver card and in the vehicle unit respectively for each:

- Day
- Driver
- Vehicle
- Change of activity

Data stored on driver card

Data is stored on the driver card when:

- 1 A driver card is inserted or withdrawn from the vehicle unit.
- 2 The driver activity changes or is manually entered.
- 3 Some events and malfunctions occurs.
- 4 Controls are performed by authorities.

In case of two drivers, each drivers card data is stored only on the respective card.

Insertion and withdrawal data

Data is stored for each day and vehicle:

- Date and time for the first driver card insertion and last withdrawal.
- Vehicle odometer value at first driver card insertion and last withdrawal.
- The vehicle registration number and registering member state of the vehicle.

Driver activity data

Data is stored for each day and change of driving activity:

- Date and daily presence counter.
- The total distance travelled by the driver card holder.
- The driving status at 00:00 hours or at card insertion, single driver or part of a crew.

- A record of each driving activity change:
 - Driving status: single or part of a crew.
 - Slot used in vehicle unit.
 - Card inserted or not inserted at the time of change of activity.
 - Driver activity.
 - Date and time of activity change.

Other data

- Some events and malfunctions
- Controls performed by authorities

Data stored on driver card and in vehicle unit

Data stored in vehicle unit

Data is stored in the vehicle unit when:

- 1 A driver card is inserted or withdrawn.
- 2 The driver activity changes.
- 3 Events and malfunctions occurs.
- 4 Tampering with the VU.

Vehicle speed is stored continuously.

Insertion and withdrawal data

Data is stored for each driver card:

- Card holders surname and first name.
- Driver card number, card issuing member state and the card expiry date.
- Date and time at driver card insertion and withdrawal.
- Vehicle odometer value at driver card insertion and withdrawal time.
- The vehicle registration number and registering member state of the vehicle.
- Card withdrawal time for the last vehicle in which the driver card was inserted.

- In which slot is the driver card inserted.
- Indication if manual entries of activities have been made.

Driver activity data

Data is stored for each day and change of driving activity:

- Driving status: single or part of a crew
- Slot used in vehicle unit.
- Card inserted or not inserted at the time of change of activity.
- Driver activity.
- Date and time of activity change.

Other data

- VU and driver card events and malfunctions.
- Detailed vehicle speed.
- Vehicle overspeeding for more than 1 minute.
- Company and workshop events.
- Tampering with the VU.

Appendix

Responsible authorities

If the driver card is lost or damaged you have to request to the responsible authority, in the country where your driver card was issued, for:

- A temporary permit to drive without a driver card.
- A replacement card.

If the driver card is stolen you also have to report to the police in the area where theft occurred and obtain a police report number.

Country	Authority	Phone number	Address
Austria	Landesgendarmerie-kommando	Phone: +43 (0)800 215359 Fax:	Verkehrsabteilung Alpenstrasse, 88 5020 - Salzburg, Austria E-mail: Website:
Belgium	SPF Mobilité et Transports	Phone: +32 (0)2 2773111 Fax : +32 (0)2 2774048	City Atrium - Rue du Progrès, 56 1210 - Bruxelles, Belgium Department : Direction générale Transport Terrestres > Transport par Route E-mail: Website:
Cyprus	Ministry of Labour & Social Insurance	Phone: +357 (0)22 401696 Fax: +357 (0)22 304224	Byron Avenue, 7 1463 - Lefkosia, Cyprus Department : Department of Labour Relations Expertise : Enforcement Authority E-mail: info@dlr.mlsi.gov.cy Website: www.mlsi.gov.cy

Responsible authorities

Country	Authority	Phone number	Address
Denmark	Danish National Police	Phone: Fax:	Ellebjergvej, 52 2450 - Copenhagen SV, Denmark Department : Traffic Division Expertise : Enforcement Authority E-mail: Website: www.politi.dk
Estonia	Central Law Enforcement Police	Phone: +372 (0)6123900 Fax: +372 (0)6123999	Ädala, 4e 10614 - Tallinn, Estonia Department: Digital Tachograph Project Expertise: Enforcement Authority E-mail: julgestuspolitsei@jp.pol.ee Website: www.pol.ee
Finland	Ministry of Social Affairs & Health	Phone: +358 (0)9 16001 Fax: +358 (0)9 72511	PO Box 556 - Uimalankatu 1, 33101 - Tampere, Finland Department : Occupational Safety and Health Expertise : Enforcement Authority E-mail: kirjaamo.stm@stm.fi Website: www.stm.fi

Responsible authorities

Country	Authority	Phone number	Address
France	Ministry of Transport	Phone: +33 (0)1 40811390 Fax: +33 (0)1 40811066	Arche Sud 92055 LA DEFENSE CEDEX, France E-mail: Website: www.transports.equipement.gouv.fr
Germany	BAG - Bundesamt für Güterverkehr	Phone: +49 (0)22157760 Fax: +49 (0)22157761777	Werderstrasse 34 - 50672 Köln, Postfach 19 01 80 - 50498 Köln, Germany Department: Digital Tachograph Project Expertise: Enforcement Authority E-mail: Website: www.bag.bund.de
Iceland	Public Roads Administration	Phone: +354 (0)5221000 Fax: +354 (0)5221049	Borgartuni, 5-7 105 - Reykjavik, Iceland Department : Digital Tachograph Project Expertise : Enforcement Authority E-mail: vegagerdin@vegagerdin.is Website: www.vegagerdin.is
Ireland	Department of Transport	Phone: + 353 (0)1 670 7444 Local phone: 1890 443 311	Transport House, Kildare St., Dublin 2, Ireland E-mail: info@transport.ie Website: www.transport.ie

Responsible authorities

Country	Authority	Phone number	Address
Italy	Department of infrastructure and transport	Phone: +39 (0)641584303 Fax: +39 (0)641584312	Via Caraci, 36 00157 Rome, Italy E-mail: Website: www.infrastrutturetrasporti.it
Latvia	Road Transport Administration	Phone: + 371 (0)7280485 Fax: + 371 (0)7821107	48/50 Brivibas St., Riga, LV-1011, Latvia E-mail: atd@atd.lv Website: www.atd.lv
Luxembourg	Direction des Douanes et Accises	Phone: +352 (0)290191-241 Fax: +352 (0)290191-234	Boîte postale 1605 L-1016 Luxembourg E-mail: Website: www.do.etat.lu
Malta	Malta Transport Authority	Phone: +356 (0)2560 8000 Fax: +356 (0)2125 5740	Sa Maison Road Floriana CMR 02, Malta E-mail: info@maltatransport.com Website: www.maltatransport.com
The Netherlands	Transport and Water Management	Phone: +31 (0)703512666 Fax: +31 (0)7030512777	PO Box 10700 2501 HS The Hague, The Netherlands E-mail: Website:

Responsible authorities

Country	Authority	Phone number	Address
Norway	National Police Directorate	Phone: Fax:	Post Box 8051 Dep, 0031 - Oslo Norway E-mail: Website: www.politi.no
Poland	General Inspectorate of Road Transport	Phone: +48 (0)22 6301370 Fax: +48 (0)22 6301389	Chalubinskiego, 4 00-928 - Warsaw, Poland Department : Inspection Supervision Office E-mail: info@gitd.gov.pl Website: www.gitd.gov.pl
Slovakia	National Labour Inspectorate	Phone: Fax:	PO Box C3 - Masarykova 10, 041 33 - Kosice, Slovakia Department: External Relations/Labour Protection Info Centre Expertise: Enforcement Authority E-mail: Website:
Slovenia	Prometni inšpektorat	Phone: +386 (0)1 4788000 Fax: +386 (0)1 4788149	Tržaška 19a P.P. 355 1000 Ljubljana, Slovenia E-mail: Website: www.gov.si/mpz

Responsible authorities

Country	Authority	Phone number	Address
Spain	Ministerio de Fomento	Phone: +34 (0)915978787 Fax: +34 (0)915978573	Paseo de la Castellana, 67 28071 - Madrid, Spain Department: Road Transport Dpt Expertise: Enforcement Authority E-mail: atencionciudadano@mfom.es Website: www.fomento.es www.fomento.es/tacografodigital
Sweden	Swedish National Police Board	Phone: +46 (0)8 4019000 Fax: +46 (0)8 4019099	PO Box 12256, 10226 - Stockholm, Sweden Department: Policing Management Division Expertise: Enforcement Authority E-mail: rikspolisstyrelsen@rps.police.se Website: www.rikspolisstyrelsen.polisen.se
Switzerland	FEDRO Swiss Federal Roads Authority	Phone: +41 (0)31 3229411 Fax: +41 (0)31 3232303	DFS - Digital Tachograph CH-3003 Berne, Switzerland E-mail: info@astra.admin.ch Website: www.astra.admin.ch www.dfs.astra.admin.ch

Appendix

Responsible authorities

Country	Authority	Phone number	Address
United Kingdom	Vehicle & Operator Services Agency	Phone: +44 (0)117 9543200 +44 (0)870 6060440 Fax: +44 (0)117 9543212	Berkeley House Croydon Street Bristol, BS5 0DA, UK E-mail:enquiries@vosa.gov.uk Website:www.vosa.gov.uk

Available countries

The VU enables you to select the following countries as your location.

If no data is entered, UNK (unknown) will be shown.

Country	
A	Austria
AL	Albania
AND	Andorra
ARM	Armenia
AZ	Azerbaijan
B	Belgium
BG	Bulgaria
BIH	Bosnia and Herzegovina
BY	Belarus
CH	Switzerland
CY	Cyprus
CZ	Czech Republic
D	Germany
DK	Denmark

Country	
E	Spain Also see “Spanish regions” on the following page.
EC	European Community
EST	Estonia
EUR	Rest of Europe
F	France
FIN	Finland
FL	Liechtenstein
FR	Faeroe Islands
GE	Georgia
GR	Greece
H	Hungary
HR	Croatia
I	Italy
IRL	Ireland

Country	
IS	Iceland
KZ	Kazakhstan
LT	Lithuania
L	Luxembourg
LV	Latvia
M	Malta
MC	Monaco
MD	Republic of Moldova
MK	Macedonia
N	Norway
NL	The Netherlands
P	Portugal
PL	Poland
RO	Romania
RSM	San Marino
RUS	Russian Federation

Appendix

Available countries

Country	
S	Sweden
SK	Slovakia
SLO	Slovenia
TM	Turkmenistan
TR	Turkey
UA	Ukraine
UK	United kingdom, Alderney, Guernsey, Jersey, Isle of Man, Gibraltar
V	Vatican City
YU	Yugoslavia
WLD	Rest of the World

Spanish regions	
AN	Andalucía
AST	Asturias
C	Cantabria
CL	Castilla-León
CM	Castile-La-Mancha
CAT	Cataluña
AR	Aragón
CV	Valencia
EXT	Extremadura
G	Galicia
IB	Baleares
IC	Canarias
LR	La Rioja
M	Madrid
MU	Murcia
NA	Navarra
PV	País Vasco

National importers

Country	Importer	Phone number	Address
Austria	Stoneridge Electronics Ltd	Phone: +44 (0) 871 700 70 70 Fax: +44 (0) 870 704 00 02	Claverhouse Industrial Park DUNDEE, DD4 9UB Scotland E-mail: sales@elc.stoneridge.com
Belgium	Phelect	Phone: +32 (0)87 56 02 74 Fax: +32 (0)87 56 02 73	Route de Herbestahl 160 4700 Eupen Belgium E-mail:
Bosnia	See Croatia.		
Czech Republic	Hale spol. s r o.	Phone: +420 (0)10 422875415 Fax: +420 (0)10 422875415	Delnicka 15 170 00 PRAHA 7 Czech Republic E-mail: doubner@hale.cz
Croatia	Auto Konzalting D.O.O.	Phone: +385 (0)1 30 77 124 Fax: +385 (0)1 30 77 124	Hamamanova 26 1000 ZAGREB Croatia E-mail:

Appendix

National importers

Country	Importer	Phone number	Address
Cyprus	K A Hiras Parts Ltd.	Phone: +357 (0)5 571230 Fax: +357 (0)2 335600	Soudas 16B LIMASSOL 3048 Cyprus E-mail: k.a.hiras@cytanet.com.cy
Denmark	BG Teknik Aarhus Aps	Phone: +45 (0)87418055 Fax: +45 (0)86174444	Grenavej 148 Postbox 2116 8240 RISSKOV Denmark E-mail: an@bgdk.com
Estonia	Lajos AS	Phone: Fax:	Jaama 18 KUNDA 44106 Estonia E-mail:
Finland	Piirla Oy	Phone: Fax:	Hopeakatu 4 KUOPIO 70150 Finland E-mail: hannu.seitsamo@scanauto.fi

National importers

Country	Importer	Phone number	Address
Germany	Stoneridge Electronics Ltd	Phone: +44 (0)871 700 70 70 Fax: +44 (0)870 704 00 02	Claverhouse Industrial Park DUNDEE, DD4 9UB Scotland E-mail: sales@elc.stoneridge.com
Greece	P Theodosiou Ltd	Phone: +30 (0)2 103474500 Fax: +30 (0)2 103477315	115 Athinon Avenue 115 ATHENS Greece E-mail:
Hungary	Szelpo Auto Control Systems Co Ltd	Phone: +36 (0)22 500 863 Fax: +36 (0)22 500 862	Budai ut 390 8000 SZEKESFEHERVAR Hungary E-mail: szelpo@mail.datatrans.hu
Ireland	MMC Commericals	Phone: +353 (0)1 4 565111 Fax: +353 (0)1 4 501035	John F Kennedy Driver Naas Road DUBLIN 12 Ireland E-mail:
Latvia	Nord Trans SIA	Phone: +371 (0)756 3753 Fax: +371 (0)756 6012	Braslas iela 22 LV-1035 RIGA Latvia E-mail: ntrans@ilad.lv

Appendix

National importers

Country	Importer	Phone number	Address
Lithuania	Vectis UAB Uzdaroji Akcine Bendrovedlvr	Phone: +370 (0)37 373300 Fax: +370 (0)37 473141	54 Ateities Road KAUNAS, LT-52105 LITHUANIA E-mail:
Luxembourg	See Netherlands.		
Macedonia	See Croatia.		
Malta	Ucimo Overseas Ltd	Phone: Fax:	Ucimco Buildings Valley Road B'KARA MALTA BKR14 E-mail: cheryl.vella@pater.com.mt
Netherlands	Casu-Utrecht B V	Phone: +31 (0)30 288 4470 Fax: +31 (0)30 289 8792	Ravenswade 118 3439 LD NIEUWEGEIN Netherlands E-mail:
Norway	Instek A.S.	Phone: +47 (0)628 16833 Fax: +47 (0)628 12250	Boks 1227 Morveien 6 2201 KONGSVINGER Norway E-mail:

National importers

Country	Importer	Phone number	Address
Poland	Neris Pl	Phone: +48 (0)2266 222 99 Fax: +48 (0)2266 222 99	M Spisaka 90A 02-495 WARSZAWA Poland E-mail: neris@neris.pl
Portugal	Lusilectra	Phone: +351 (0)226 198 750 Fax: +351 (0) 226 158 669	Rua Eng. Ferreira Días 953/993 40100 - Porto Portugal E-mail:
Serbia	See Croatia.		
Slovenia	See Croatia.		
Sweden	Magnum Trade AB Industri Elektronik	Phone: +46 (0)8 154400 Fax: +46 (0)8 154403	Box 19106 104 32 STOCKHOLM Sweden E-mail:
Yugoslavia	See Croatia.		
Switzerland	Autometer AG	Phone: +41 (0)41 349 40 50 Fax: +41 (0)41 349 40 60	Grabenhofstrasse 3 6010 - Kriens Switzerland E-mail:

- A**
- Accept default times** 47
 - Activities**
 - Add 46
 - Automatically selected 18
 - Change in manual entries 45
 - Change of, during working day 28
 - Definition 18
 - Delete 46
 - Manually selectable 18
 - Not entered in time 11, 22
 - Printing 51
 - User scenarios 25
 - Add activities** 46
 - ADR version**
 - Driver card slots locked 23
 - Operating temperature 8
 - Special features 88
 - TÜV certificate 88
 - Approval** 8
 - Authorities** 92
- B**
- Buttons**
 - Down 15
 - Driver 1 15
 - Driver 2 15
 - Enter 15
 - If disabled 23
 - Quit 15
 - Up 15
- C**
- Cancel**
 - Modify manual entries 47
 - Card slots** 15
 - Care**
 - Driver card 20, 80
 - Vehicle unit 20, 80
 - Certification** 8
 - Change of**
 - Activity during working day 28
 - Activity in manual entries 45
 - Displays when in motion 62
 - Printer paper roll 81
 - Change to**
 - Main menu display 17
- Country**
- Available in VU 99
 - Entering 44
 - Outside EU 19, 49
- D**
- Definition**
 - Activities 18
 - Working day 18
 - Delete**
 - Activities 46
 - Manual entries 46
 - Display** 58
 - Last card withdrawal >24h 24
 - Display appearance**
 - Negative or positive view 58
 - Display in instrument cluster** 13
 - Displays**
 - Break time 62
 - Change 16, 62
 - Driving time 62
 - List of 62
 - Main menu 17
 - Speed 62
 - Standard 16, 62
 - UTC time 62
 - When in motion 62
 - Driver buttons** 15

- Driver card** 13
 Care 20, 80
 Insert 23
 Stolen, lost, damaged 11
 Withdraw 29
- Driver card slot** 15
- Driver card slots locked** 23
- Driving**
 Easy use of tachograph 10, 22
 Non public road 19, 49
 Normal working day 10
 Not permitted 11
 Outside EU 19
 outside EU 49
 Partly loaded 19, 49
 Recording not required, see Out of Scope driving
 Temporary without driver card 11
- Driving regulations** 10
- E**
- Easy use of tachograph** 10, 22, 30
- Electromagnetic compatibility** 8
- Enter the country** 44
- EU**
 Driving outside 19, 49
 Regulation 11
- Exit**
 Modify manual entries 47
- F**
- Ferry journey** 48
- Ferry/train mode**
 Activate 48
 Deactivate 48
- H**
- Hazardous goods version**
 see ADR version
- I**
- Importers** 101
- Insert**
 Paper roll 82
- Insert driver card** 23
- Installation plaque** 7
- J**
- Journey**
 Ferry or train 48
 Outside EU 19, 49
- L**
- List of**
 Displays 62
 Messages, warnings and malfunctions 66
 Symbol combinations 65
 Symbols 63
- Local time**
 Settings 58
- M**
- Main menu display**
 Begin place 17
 End place 17
 Ferry/train or Out of scope 17
 Print menu 17
 Settings 17
- Malfunctions**
 List of 66
- Manual entries**
 Accept default times 47
 Add 46
 Cancel modify mode 47
 Delete 46
 Exit modify mode 47
 Modification not possible 45
 Overview 30
 Save 46

- Messages**
 - List of 66
- N**
- Normal**
 - Driving 10
 - Working day 10
- O**
- Operating temperature** 8
- Out of scope driving**
 - Activate 49
 - Deactivate 50
 - Non public road 19, 49
 - Outside EU 19, 49
 - Partly loaded vehicle 19, 49
- P**
- Paper cassette** 15
 - Remove 81
- Paper roll** 80
 - Change 81
 - Insert 82
- Power saving mode** 10, 22
- Power supply**
 - interruption of 7
- Printer**
 - Paper cassette 15, 80
 - Paper change 81
 - Paper roll 80
 - Printouts 51
 - Replacement parts 80
- Printouts**
 - Create 51
 - Show on display 51
 - Show on Paper 51
 - Types of 53
- Q**
- Quit**
 - Button 15
- R**
- Recording not required, see Out of Scope driving**
- Remove paper cassette** 81
- Repairs** 7
- Replacement parts for printer** 80
- Responsible authorities** 92
- S**
- Save manual entries** 46
- Scenarios of user activities** 25
- Security inspection** 7
- Self-test** 83
- Settings**
 - Display appearance 58
 - Local time 57
 - UTC time 57
- Slots**
 - If locked 23
- Speed sensor** 13
- Stand by mode, see Power saving mode**
- Standard display** 16, 62
- Stoneridge importers** 101
- Symbols**
 - Combinations 65
 - Meaning 63
- System overview**
 - Display in instrument cluster 12
 - Driver card 12
 - Speed sensor 12
 - Vehicle unit 12
- T**
- Train journey** 48
- Troubleshooting** 83
- U**
- User** 32
- User activities scenarios** 25

UTC time

Settings 57

V

Vehicle 13

Vehicle unit 13

Buttons 15

Card slots 15

Care 20, 80

Display 15

Main menu display 17

Paper cassette 15

Standard display 16

User interface 15

VU, see Vehicle unit

W

Warnings

List of 66

Withdraw driver card 29

Working day

Continuing present 32

Definition 18

Easy use of tachograph 10, 22

New, with previous activities 33

New, without previous activities 28

Normal 10

Scenarios 25



Stoneridge Electronics Ltd

Charles Bowman Avenue
Claverhouse Industrial Park
Dundee Scotland DD4 9UB

Tel: +44 (0)871 700 7070 Fax: +44 (0)870 704 0002

E-mail: sales@elc.stoneridge.com

www.stoneridgeelectronics.info

9000-101587/01R08