

Driver & Company Manual

SE5000 Digital Tachograph



Stoneridge - Setting the standard
www.SE5000.com



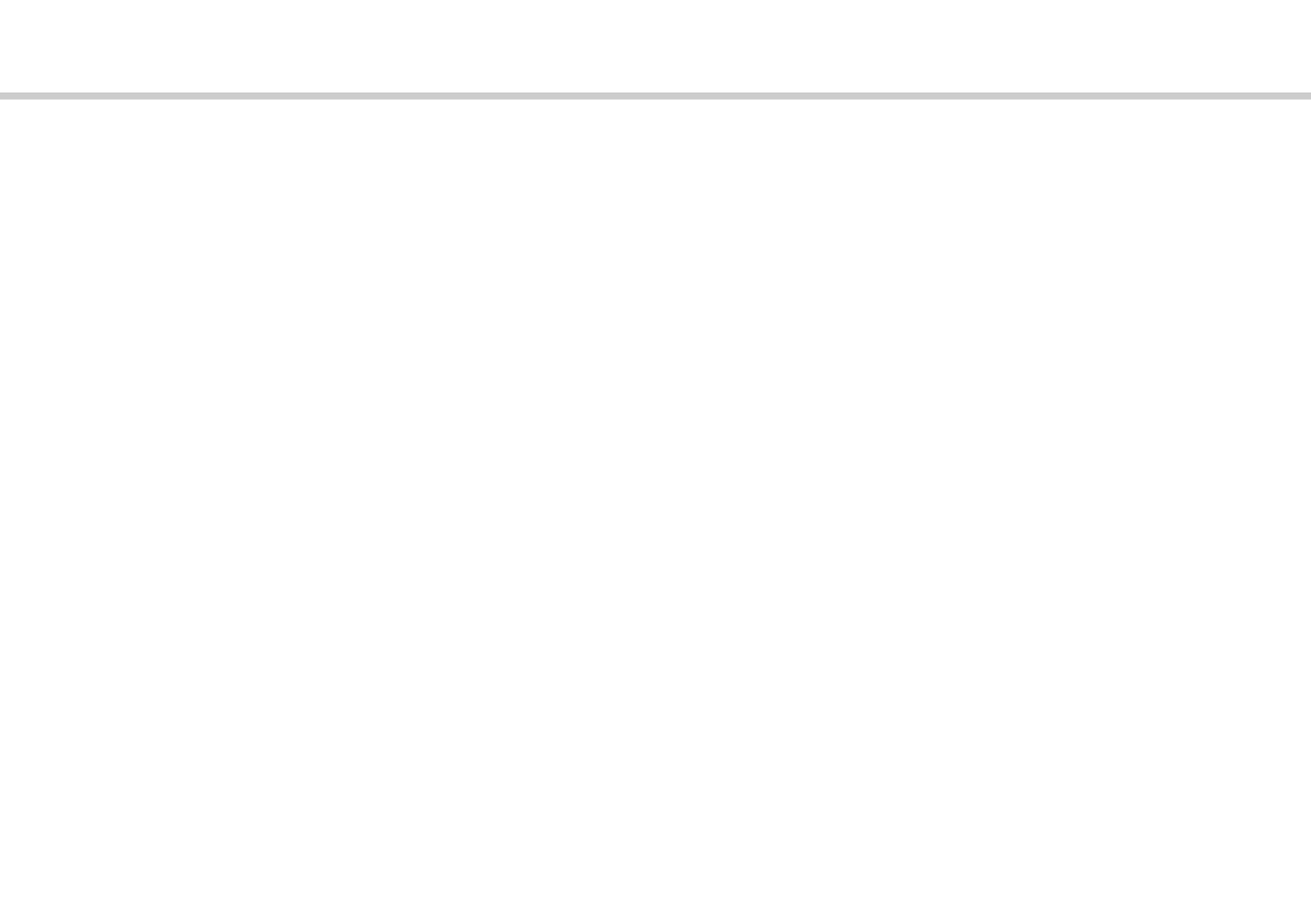

Certified User Manual



This User Manual is an extended version of the certified User Manual 9000-102019/01 04, and have been produced to meet the demands of our customers.

The certified version can be found on the Internet at: www.SE5000.com

Thank you for choosing the Stoneridge Digital Tachograph SE5000.

At Stoneridge we believe in working with drivers and fleets to deliver products to help make your life easier. Your SE5000 has been designed with you in mind with simple menu options, high speed downloads, remote download capability as just a few examples. To get the most of your unit, we recommend that you familiarise yourself with how to operate the digital tachograph - before starting your first journey.

Using this Manual.

Please read this Driver & Company Manual before driving off. This will help you to obtain the maximum use from your tachograph and avoid endangering yourself and others.

Stoneridge Electronics reserves the right to introduce changes in design, equipment and technical features at any time. You cannot, therefore, base any claims on the data, illustrations or descriptions in this Driver & Company Manual.

The local Stoneridge representative will be pleased to assist you if you should have any questions.

Keep this Driver & Company Manual in the vehicle. If the vehicle is sold, pass this manual on to the new owner, as the tachograph is considered as a part of the vehicle.

Symbols



Warning



Important information



Tip



Action required



Page reference

Display Messages in the display

VU Vehicle Unit (Digital Tachograph)

Definitions in these instructions

Driver

The person who is currently or will be driving the vehicle.

Co-driver

The person who is not driving the vehicle.

Working day

A number of activities carried out by driver and co-driver in a daily work period.

Activity

With what the driver is occupied.

Contact Stoneridge

You are welcome to forward any queries or suggestions you may have about the tachograph and the operating instructions to any of our sales offices, as listed below.

United Kingdom

Stoneridge Electronics Ltd
Charles Bowman Avenue
Claverhouse Industrial Park
Dundee, Scotland
UK

Phone: +44 (0)871 700 7070

Fax: +44 (0)870 704 0002

e-mail: sales@stoneridge.com

France

Stoneridge Electronics France
Z.I St. Etienne
F-64100 Bayonne
France

Phone: +33 (0)5 59 50 80 40

Fax: +33 (0)5 59 50 80 41

e-mail: france.amsales@stoneridge.com

Germany

IVEKA Automotive Technologies
Schauz GmbH
Talweg 8
D-75417 Mühlacker-Lomersheim
Germany

Phone: +49 (0)7041 9695-0

Fax: +49 (0)7041 9695-55

e-mail: info@iveka.de

Italy

Stoneridge Electronics s.r.l.
Viale Caduti nella Guerra di Liberazione,
568
00128 Rome
Italy

Phone: +39 0 650861001

Fax: +39 0 650861006

email: italy.amsales@stoneridge.com

Netherlands

C.A.S.U. - Utrecht b.v.
Ravenswade 118
NL-3439 LD Nieuwegein
Netherlands

Phone: +31 (0)30 288 44 70

Fax: +31 (0)30 289 87 92

e-mail: info@casuutrecht.nl

Spain

Stoneridge Electronics España
Avda. Severo Ochoa 38
Pol. Ind. Casa Blanca
28108 Alcobendas
Madrid
Spain

Phone: +34 91 662 32 22

Fax: +34 91 662 32 26

e-mail: spain.amsales@stoneridge.com

Sweden

Stoneridge Nordic AB
Gårdsfogdevägen 18 A
SE-168 66 Stockholm
Sweden

Phone: +46 (0)8 154400

Fax: +46 (0)8 154403

E-mail: kontakt@stoneridge.com

Information on the Internet

Further information about
Stoneridge Digital Tachograph SE5000 and
about Stoneridge Electronics Ltd can be
found at:

www.SE5000.com

www.stoneridgeelectronics.info

Copyright

Not to be reprinted, translated or otherwise
reproduced in whole or in part, without writ-
ten permission from
Stoneridge Electronics AB.

Please refer also to the index

(▷ page 139).

Introduction		Modify Manual Entries	34
Operating Safety	9	Confirm Entries	34
Repairs and Modifications	9	Change an Entry	35
Workshop Periodic Inspection	9	Clear all Entries	37
Technical data	10	Journey with Ferry or Train	38
At a Glance		Ferry/Train Activity	38
System Overview	12	Driving where no Recording is Re-	
Encrypted Motion Sensor (1)	13	quired	39
Digital Tachograph (2)	13	Driving Out of Scope	39
Display in Instrument Cluster (3) ...	13	Printouts	40
Driver Card (4)	13	Create a printout	40
User Interface Overview	14	Types of printout	42
Standard Display	16	Printout Example	45
Tachograph Menu	17	Settings	68
Controls		Settings	68
Working Day Activities	20	Language	68
Insert a driver card	20	Change UTC Time	69
User Scenarios Overview	21	Change Local Time	70
Normal Working Day	21	Invert Display	71
Change of activity	23	Displays and Data	
Change of Places	24	Displays	74
Withdraw a driver card	25	Driver Displays	74
Perform Manual Entries	27	Symbols	76
Manual Entries Scenarios	27	Symbols	76
Manual Entries Procedure	28	Symbol Combinations	78
		Messages, Warnings and Malfunc-	
		tions	79

Three Types of Notifications	79	Data Stored on Driver Card	111
Messages	79	Data Stored in Tachograph	112
Warnings	79	National Importers	113
Malfunctions	79	National Importers	113
Practical Advice		Time Zones	123
Changing the Paper Roll	94	Time Zones	122
Remove the Paper Cassette	94	Company Mode	
Insert a Paper Roll	94	Requirements and Recommendations	124
Maintenance and Care	96	Owner's Responsibility	124
Replacement Parts for Printer	96	Company Functions	126
Care for card	96	Lock-in Data	128
Care for tachograph	97	Lock-in Data	128
Built-in Test	98	Lock-out Data	130
Built-in Test	98	Download Data	131
Frequently asked Questions ...	101	Download Data	131
Appendix		Settings	134
Available Countries	106	Settings	134
Available Languages	108	Tachograph Inspection	137
ADR Tachograph	109	Tachograph Inspection	137
Approved for Use in Hazardous Goods Vehicles	109	Company Functions Data	138
Special features of the ADR Tachograph	109	Index	
Data stored on Driver Card and in Tachograph	111	Index	139

Operating Safety

Operating Safety

Risk of accident

Do not operate the tachograph unless the vehicle is stationary. Your attention would otherwise be diverted from the road and traffic conditions and you could therefore cause an accident.

Repairs and Modifications

The tachograph has been installed by authorised personnel.

A tachograph case must never be opened. No tampering with or modifications to the tachograph system are permitted.

A tamper label is placed inside the printer-housing. The tamper label must not be torn apart.



Persons that modify this equipment are committing a punishable offence, depending on the legislation in the country concerned.

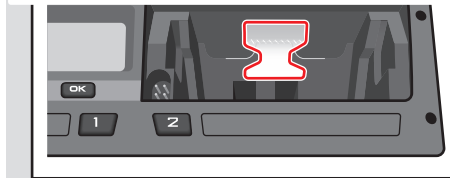
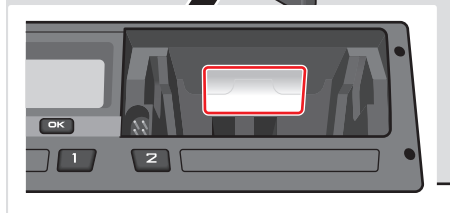
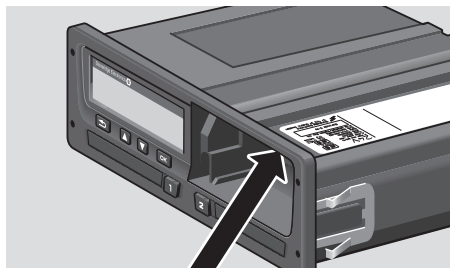

101808/060R01

Tamper label

Workshop Periodic Inspection

The tachograph must be checked by a digital tachograph workshop at least every 2 years.

The installation plaque, fixed near the tachograph, states the date for passed inspection.



101808/040R01

At the inspection the installation plaque must be valid and not broken.

Technical data

Version of tachograph

Digital Tachograph SE5000

Operating temperature

-25°C to +70°C

Hazardous goods version in accordance with ADR: -25°C to +65°C

Certification and approval

The tachograph is approved for use in the European Union and certified to ITSEC “level E3 high” in accordance with EU legislation.

Type approval number: e5-0002

Electromagnetic compatibility

The tachograph fulfils the requirements of EU Commission Directive 72/245/EEC, last amended by Directive 2006/96/EC, certificate No 03 0289, in respect of electromagnetic compatibility.

System Overview

User Interface Overview

System Overview

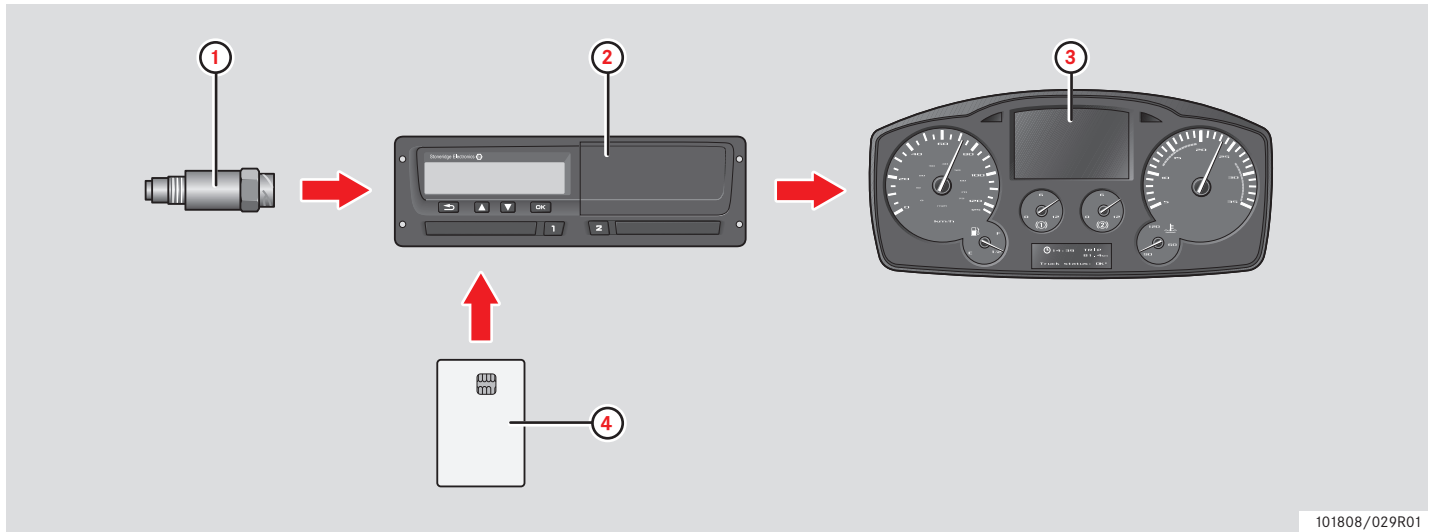

101808/029R01

1	Encrypted motion sensor
2	Tachograph, with integrated display and printer

3	Display in vehicle's instrument cluster
4	Driver card

System Overview

Encrypted Motion Sensor (1)

The encrypted motion sensor transfers the speed pulses to the tachograph. Tampering with the sensor or the signal is detected by the tachograph and recorded.

Digital Tachograph (2)

The tachograph records and stores various data:

- Driver card data, except from driving license data.
- Warnings and malfunctions related to the tachograph, the driver, the company and the workshop.
- Vehicle information, odometer data and detailed speed for 24 hours.
- Tampering with the tachograph.

Special features for the ADR Tachograph, see ▷ ADR Tachograph, page 109



Over speeding for more than one minute will be stored in the tachograph.

Show Tachograph Data

The tachograph data can be shown in the tachograph display and on printouts.

▷ Create a printout, page 40

Display in Instrument Cluster (3)

The vehicle's instrument cluster displays, in different ways depending on the ability of the vehicle, the following information from the tachograph:

- Speed
- Distance travelled
- Messages, warnings and malfunctions

Driver Card (4)

The driver card uniquely identifies the driver and stores various data under the driver's name:

- Driving time, activities and distance.
- Drivers license information.
- Some warnings and malfunctions.
- Vehicle Registration Number (VRN) for vehicles used by the card holder.
- Controls performed by authorities.



The drivers card can store data typically up to 28 days. After this time, the oldest data is over written when new data is stored.

Detailed information regarding tachograph and driver card data can be found in the appendix.

▷ Data Stored on Driver Card, page 111



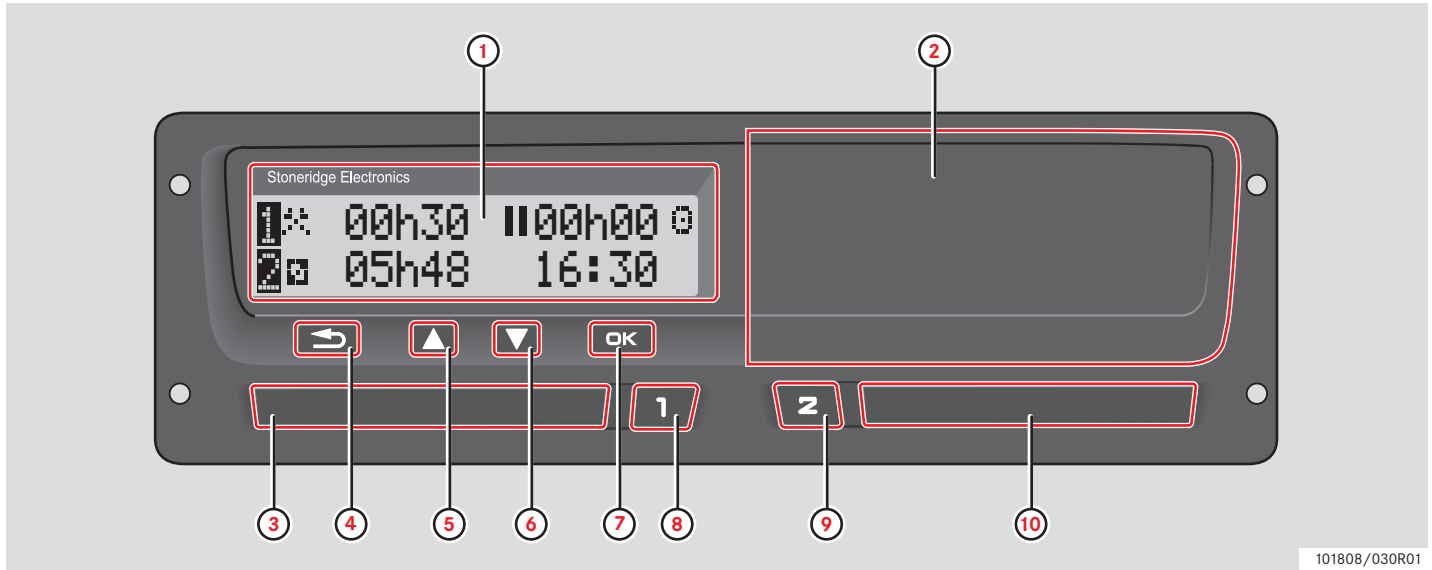

User Interface Overview



101808/030R01

User Interface Overview

		Page
1	Display	
	Driver's standard display	16
	Tachograph menu	17
	Messages, warnings and malfunctions	79
2	Printer	
	To create a printout	40
	To insert/change a paper roll	94
3	Driver card tray	
	To insert /withdraw a driver card	20/ 25
4	Return 	
	To cancel a process	-
	To quit a process	-
	To move backwards in a display	-
	To return to the previous display	-

		Page
	To return to the standard display (press repeatedly)	-
5	Up 	
	To increase values	-
	To highlight and select options	-
6	Down 	
	To decrease values	-
	To highlight and select options	-
7	OK 	
	To confirm entries	-
	To clear messages or warnings	79
	To acknowledge malfunctions	79
8	Driver 	
	To open driver tray	20
	To change driver activities	23

		Page
9	Co-driver 	
	To open the co-driver tray	20
	To change co-driver activities	23
10	Co-driver card tray	
	To insert/withdraw a driver card	20/ 25

Standard Display

Press any button to activate the display.

The driver standard display is shown:

- When “NO” is selected on the “Add manual entries?” question.
- When the Manual Entries procedure is completed.
- When repeatedly pressing the  button to move backwards from an entry or a tachograph menu item.
- As soon as the vehicle is set in motion.

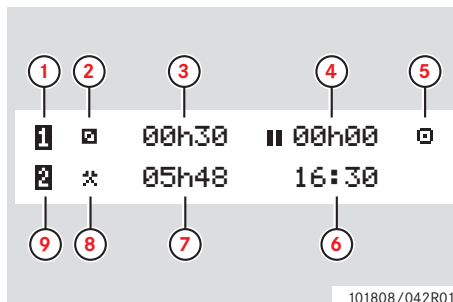

- 1 Driver
- 2 Driver's activity
- 3 Duration of driver's activity
- 4 Cumulative break time for the driver in a working day
- 5 Operating mode of tachograph (Operational)
- 6 Local time
- 7 Duration of co-driver's activity
- 8 Co-driver's activity
- 9 Co-driver

Other Displays

There are four other displays available showing the following information:

	Page
Driver 1 Cumulative Drive and Break times	74
Driver 2 Cumulative Drive and Break times	74
UTC and Local time and date	74
Speed, odometer and inserted card indication display	74

Menus, Symbols and Notifications

The tachograph has three menus available. The display can also show a vary of symbols and messages.

	Page
Tachograph menu	17
Symbols and combination of symbols	78
Messages and notifications of warnings and malfunctions	79

User Interface Overview

Tachograph Menu

The following three menus can be selected.
Press **OK** to get to the menus.

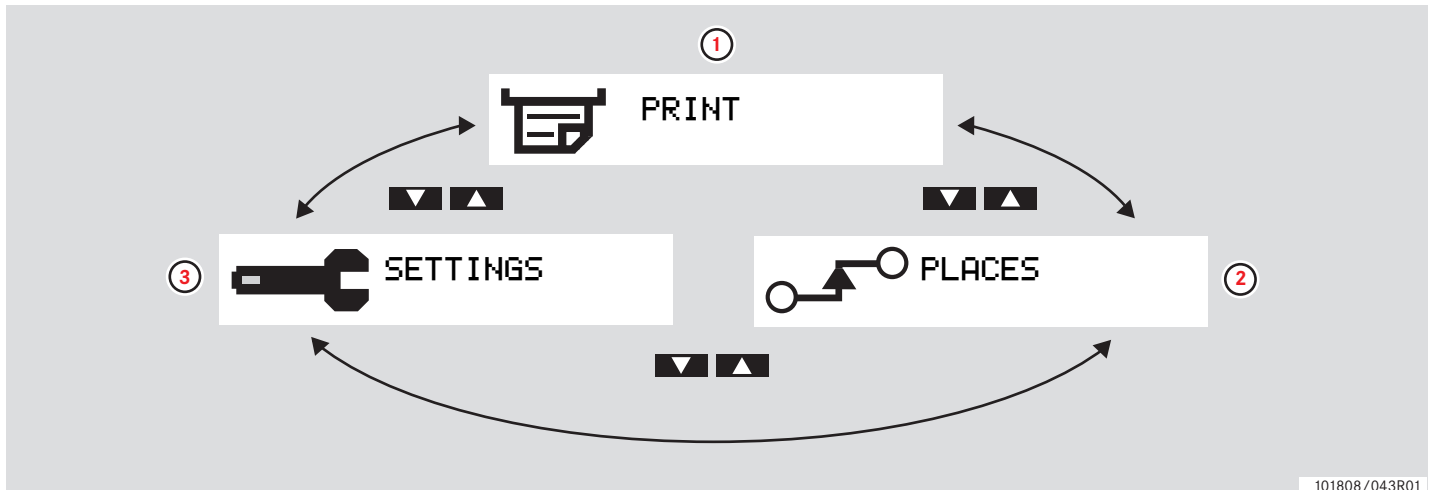

101808/043R01

		Page
1	Create a printout	40
2	Change of places	24
3	Settings	68

Working Day Activities

Perform Manual Entries

Modify Manual Entries

Journey with Ferry or Train

Driving where no Recording is Required

Printouts

Settings

Working Day Activities

Insert a driver card

- 1 Press and hold the **1** button for the driver card tray or the **2** button for the co-driver card tray until the tray ejects.
- 2 Insert the card with the chip facing forward and upwards.

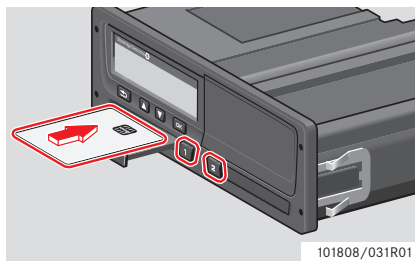

- 3 Close the tray by pushing it carefully.

The tachograph processes the driver card data.

If the driver card authentication fails, see

▷ page 81



The drivers card must always be inserted in tray **1** !

A working day is defined by the activities the driver and the co-driver have done. Some activities are automatically selected, others must be entered manually.

In two-man operation, the driver inserts the card into the tray on the left-hand side **1** and the co-driver into the tray on the right-hand side **2**.



The driver cards must be swapped if there is a change of drivers.

Each activity is defined by an activity type, a start time and an end time.

Symbol	Activity type
	Work Activity while the vehicle is stationary, e.g. loading the vehicle.
	Driving Driving the vehicle.
	Rest/break For breaks.
	Available Passive activity before or after the journey commences, e.g. waiting for paperwork to be completed.

Working Day Activities

User Scenarios Overview

Use one of the following user scenarios as guidance:

- Normal Working Day Scenario
- (▷ Manual Entries Scenarios, page 27)



During a normal working day a driver card must be inserted in the tachograph.

The driver card is personal and may not be used by anyone else but the rightful card holder.



Drivers are responsible for ensuring that they obey driving laws in respective country.

Normal Working Day

The user scenario shown below is the scenario for a new working day.

▷ Initial Procedure, page 22

The driver card was withdrawn at the end of the last working day and inserted when the new working day started.

All previous activities have been stored and there is no need for manual entries.

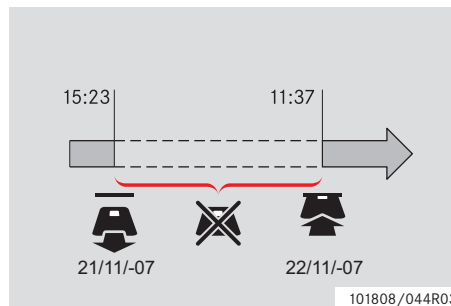

During a normal working day:

- The driver card must be inserted in the tachograph in order to identify the driver.

- All changes of activities must be entered at the time of the change.

Driver card Inserted

For periods when the driver card has been inserted, the already stored activities cannot be changed.

No driver card inserted

If activities have been performed without the driver card inserted, these activities must be manually entered at the next driver card insertion.

The following pages describe actions and activities during a working day:

- ▷ Insert a driver card, page 20
- ▷ Change of activity, page 23
- ▷ Change of Places, page 24
- ▷ Withdraw a driver card, page 25

Initial Procedure

When a driver card has been inserted, the name of the card holder appears for a short time.

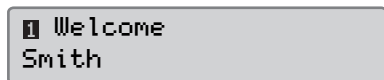

Information about the last driver card withdrawal time appears for a short time.

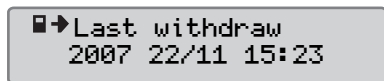

1 Press **OK** to confirm "YES".

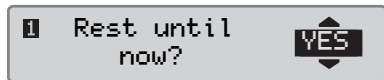

If "NO" is selected see:

▷ Manual Entries Scenarios, page 27

2 Use the **▲** or **▼** button to select "End country" and press **OK** to confirm.

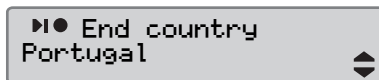

If "End country" was selected at the last card withdrawal this display does not appear.

3 Use the **▲** or **▼** button to select "Begin country" and press **OK** to confirm.



!
The "End" and "Begin country" display will not show if the time between card withdrawal and insertion falls short of nine hours.

4 Use the **▲** or **▼** to select if a printout of the entered data is wanted or not and press **OK** to confirm.

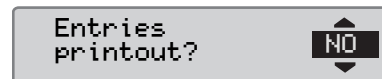

5 Use the **▲** or **▼** button to select "YES" and press **OK** to confirm and save the entries.

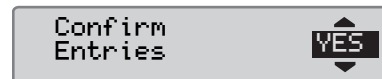

If "YES" is selected, the entries are saved and the following message appears for a short time:

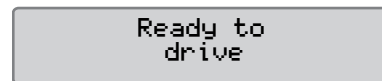

The entries are saved and the standard display will appear.





If "NO" is selected, see

▷ Manual Entries Scenarios, page 27

Working Day Activities

Change of activity**Automatically Selected Activities**

The tachograph automatically selects the activity for each driver according to the current driving situation.

Driving situation	Driver	Co-driver
Set in motion/ driving	Driving 	Available 
Stopping/ stationary	Work 	Available 



The automatically change of activity takes place:

- From Driving to Work if the vehicle has been stationary more than two minutes.
- From Work to Driving if the vehicle has been set in motion within the last minute.

Manually Selected Activities

When the vehicle is stationary, any other activity than Work for the driver or Available for the co-driver must be selected manually.

The following activities can be selected manually:

	Work
	Rest/break
	Available

To change activity during a working day do the following:

- ▶ Insert the driver card.
- ▶ Stop the vehicle.
- ▶ Press repeatedly the **1** button (driver) or the **2** button (co-driver) until the desired activity is shown in the display.



“Driving” can not be selected manually.



Change of activity can only be made when the vehicle is stationary.



The start/stop activity in ignition switch on/off can be preset by company and workshop.
Check with your company if the start/stop activity is preset!

Change of Places

It must be specified which country the vehicle is in when the working day begins and ends.

This can be done:

- Whenever during a working day from the “PLACES” sub-menus “Begin place” or “End place”.
- When automatically asked to at each driver card withdrawal.
- During manual entries of activities.



Change of places can only be made when the vehicle is stationary.

▷ Manual Entries Scenarios, page 27

Whenever During a Working Day

- 1 Press the **OK** button to show the menu.
- 2 Use the **▲** or **▼** button to select “PLACES” and press **OK**.



- 3 Use the **▲** or **▼** button to select “Begin place” or “End place” and press **OK**.

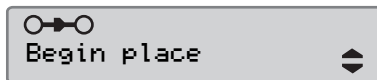

- 4 Use the **▲** or **▼** button to select actual country and then press **OK** to confirm the selection and to go back to the default display.

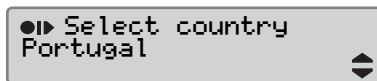

For information of available countries, see

▷ Available Countries, page 106



The tachograph menu is only available when the vehicle is stationary.



For Spain, it is also necessary to select a region.

▷ Spanish regions, page 107

Working Day Activities

Withdraw a driver card

Withdraw the driver card if there is a change of drivers. Withdrawal of the driver card is possible in Main-Menu.

- 1 Press and hold the **1** button to open the drivers tray or the **2** button to open the co-drivers tray.
- 2 Use the **▲** or **▼** button to select “End country” and press **OK**.

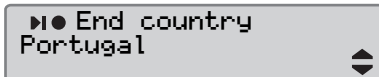

The tachograph stores the data to the driver card and then ejects the tray.

- 3 Press the driver card up slightly from underneath through the opening in the tray or push the edge of the tray down until the driver card pops out.

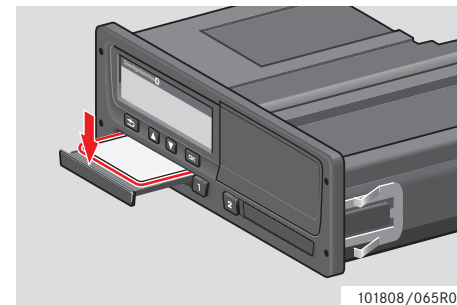
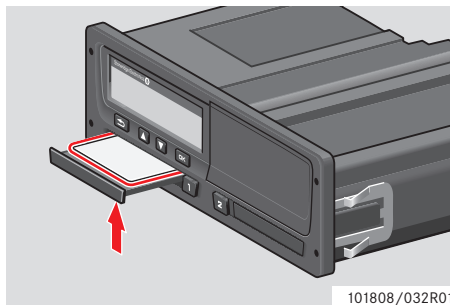

Withdraw a card:

- ▶ Remove the driver card.
- ▶ Close the tray by pushing it carefully.

Card Trays Locked

The card trays are locked:

- When the vehicle is in motion.
- While the tachograph is busy processing a driver card.
- If the power supply to the tachograph is interrupted.

▷ Special features of the ADR Tachograph, page 109

If the card is still inserted and the power supply cannot be restored, it will be necessary to have the tray unlocked by a digital tachograph workshop.

Power Saving Mode

When the ignition is switched off, the tachograph will enter the power saving mode ten minutes after the last interaction. The display illumination is off ten seconds after the last interaction. In the power saving mode the display is off.

The tachograph will be illuminated if either of the following is done:

- Press any button once.
- Switch ignition on.
- Take the vehicle in tow.

▷ Special features of the ADR Tachograph, page 109

Perform Manual Entries

Perform Manual Entries

Manual Entries Scenarios

Manual entries of activities must be done if activities without the driver card inserted have been performed.

These activities can only be entered at the the next driver card insertion.

▷ Manual Entries Procedure, page 28



Activities that have been entered with a driver card inserted cannot be changed afterwards.

Manual entries can only be done when the vehicle is stationary.



The manual entries mode is exited without completing the procedure when:

- No interaction have been done with the tachograph for 1 or 20 minutes.
- Insertion or redrawing of second card.
- Driving begins.

Limitations

There are several limitations for manual entered activities.

Earliest Start Time

The activity start time can not be set earlier than:

- The last driver card withdrawal time.
- The end time of the adjacent manually entered activity.

Latest End Time

The activity end time can not be set later than the time for the last driver card insertion.

Exit Manual Entries Procedure

The manual entries mode is normally ended when the procedure is completed.

▷ Manual Entries time out, page 135



If exiting the manual entries mode without completing the procedure, only completed entries will be stored.

Manual Entries Procedure

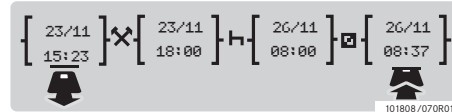
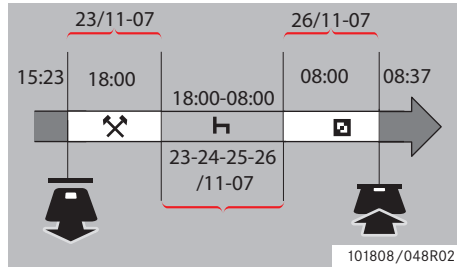

The following scenario describes a situation where you have to perform manual entries.

-You arrived on friday at 15:23 23/11-07 and withdrew the driver card.

-You performed other work until 18:00.

-You rested between 18:00 over the weekend to 08:00, monday, 26/11-07

-You were available at 08:00, 26/11-07.

-You insert the driver card at 08:37, 26/11-07.

Manual Entries

During the manual entries procedure use:

- The **OK** button to move along in the display to a date, time or activity and to confirm an entry.
- Use the **▲** or **▼** buttons to select/highlight wanted data, values and activities.
- The **←** to move back to previous display or backwards in a display.



The tachograph menu is only available when the vehicle is stationary. All manual entries in this example are entered in local time.

1 Insert the driver card.

2 Use the **▲** or **▼** buttons to select “NO” and press **OK**.

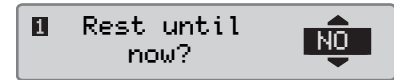

3 Use the **▲** or **▼** buttons to select “YES” and press **OK**.

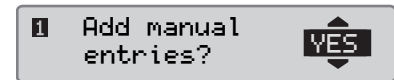

4 Use the **▲** or **▼** buttons to select “local” and press **OK**.





The following display appears:



Perform Manual Entries

The date and time in the display shows the driver card's last withdraw.

You will now enter the "other work" you performed on Friday.



- 5 Use the  or  buttons to highlight the  symbol.





- 6 Press . The following display shows:





- 7 The date in the right column is to be changed to 23/11.

To adjust the date, use the  or  buttons to scroll back to 23/11. Press  to confirm.



- 8 Next, the time (hour) is to be changed. Use the  or  buttons to scroll forwards to 18:00. Press  to confirm.







- 9 To adjust minute, use the  or  buttons to scroll to 18:00. Press  to confirm.





The following display shows after you pressed .



- 10 You will now enter the time you rested, between 18:00 23/11 to 08:00, 26/11. Use the  or  buttons to highlight the  symbol. Press  to confirm.



In this example, it is not necessary to adjust the date or hour. Confirm date and hour by pressing .

Adjust the minute to 08:00 as instructed in step 9. Press  to confirm.

The following display shows after you pressed .



Controls

Perform Manual Entries

The last step is to enter the time you were available between 08:00 to 08:37, 26/11.



- 11 Use the  or  buttons to highlight the  symbol. Press  to confirm. The following display shows:

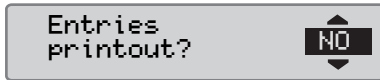

No changes are necessary since this is the time between last activity (rest) and the time when the card was inserted. Press  to confirm date and time.

- 12 The following display shows



Use the  or  to select if a printout of the entered data is wanted or not and press  to confirm.

▷ Printout, Manual Entries Confirmation, page 66

The following display shows:

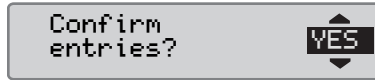

Press  to select "YES".

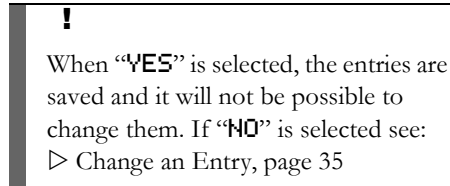

The following display shows:

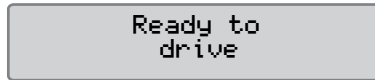

You are now ready to drive and the standard display will appear.

Perform Manual Entries

Manual Entries with Unaccounted Time

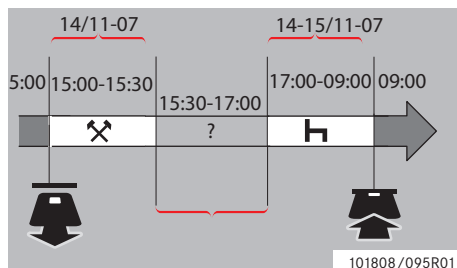

The following scenario describes a situation where you have to perform manual entries with unaccounted time. Unaccounted time is a period that will not be registered on the driver card, i.e. driving a vehicle with analog tachograph.

-You withdrew the driver card at 15:00, 14/11-07.

-You performed other work until 15:30.

-You performed other activities (unaccounted time) between 15:30 to 17:00 that will not be registered on the driver card.

-You rested between 17:00 to 09:00 15/11-07.

-You insert the driver card at 09:00, 15/11.

Manual Entries

During the manual entries procedure use:

- The **OK** button to move along in the display to a date, time or activity and to confirm an entry.
- Use the **▲** or **▼** buttons to select/highlight wanted data, values and activities.
- The **↶** to move back to previous display or backwards in a display.



The tachograph menu is only available when the vehicle is stationary. All manual entries in this example are entered in local time.

1 Insert the driver card.

2 Use the **▲** or **▼** buttons to select “NO” and press **OK**.

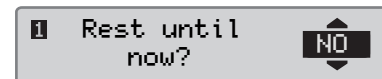

3 Use the **▲** or **▼** buttons to select “YES” and press **OK**.

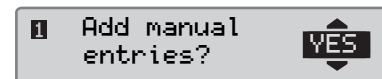

4 Use the **▲** or **▼** buttons to select “local” and press **OK**.



The following display appears:





Controls

Perform Manual Entries

The date and time in the display shows the driver card's last withdraw.

You will now enter the other work you performed on Friday.

5 Use the  or  buttons to highlight the  symbol.



6 Press . The following display shows:



7 Adjust the date and minutes as described in previous example to register the other work you have performed.

The following display shows:





You will now register the unaccounted time.

8 Press . The following display shows:



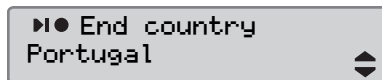

9 Press . The following display shows.

Use the  or  button to select the country you are present in.



10 Press . The following display shows.

Use the  or  button to select the country you are present in.

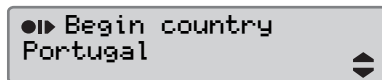

11 Press . The following display shows:



Adjust the time and date to 14/11 and 17:00



12 You will now enter the rest. Press . The following display shows:



Press  to register the rest. The following display shows:



Perform Manual Entries

13 Press **OK**. The following display shows:

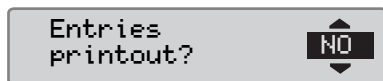

Use the **▲** or **▼** to select if a printout of the entered data is wanted or not and press **OK** to confirm.

The following display shows:

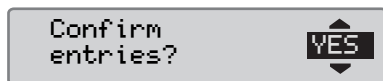

Press **OK** to select "YES".

!

When "YES" is selected, the entries are saved and it will not be possible to change them. If "NO" is selected see:
 ▷ Change an Entry, page 35

The following display shows:

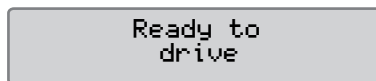

You are now ready to drive and the standard display will appear.

Modify Manual Entries

Confirm Entries

The “Confirm entries?” gives the driver an opportunity to change a specific manually entered date, time or activity, or to redo the manual entries procedure.

An already saved entry can not be changed afterwards.

To change an entry or to redo the manual entries procedure, select “NO” when the “Confirm entries?” display appears.

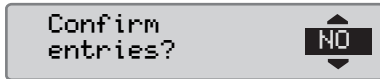

!

If “YES” is selected the entries will be saved and afterwards impossible to change.

► Scroll up or down to select “Change entry” or “Clear all entries” and confirm.

- ▷ Change an Entry, page 35
- ▷ Clear all Entries, page 37

!

Manual entries can only be modified during the ongoing manual entries procedure.

Modification of entries is not possible when:

- The entries have been saved.
- The manual entries mode is exited.
- The vehicle is set in motion.

Modify Manual Entries

Change an Entry

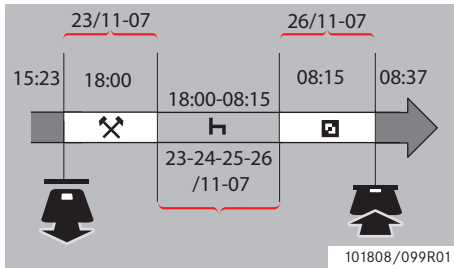

It is possible to change entries and add activities if needed. The following scenario is that you want to change the rest endtime to 08:15. This means that the available time will change.

▷ Manual Entries Procedure, page 28

- 1 Use the **▲** or **▼** buttons to select “NO” and press **OK**.

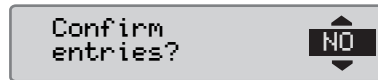

- 2 Select and confirm “Change entries”.

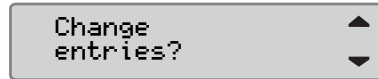

The display of the first manual entry shows:

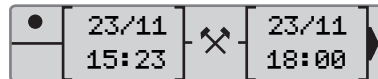

- 3 You will now change the rest endtime to 08:15.

Navigate to the rest activity by using the **▲** or **▼** buttons.



- 4 Press **OK**. The following display shows:



- 5 Press **OK**. The following display appears. Press **OK** again to reach 08:00 and change the value to 08:15.



- 6 Press **OK**. The following display shows:



Controls

Modify Manual Entries

7 Press **OK**. The following display shows:



No changes are necessary since this is the time between last activity and the time when the card was inserted.

8 Press **OK** repeatedly to get to the print-out menu.

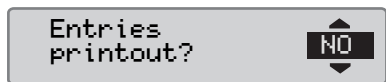

Use the **▲** or **▼** to select if a printout of the entered data is wanted or not and press **OK** to confirm.

9 Use the **▲** or **▼** to select "YES" or "NO" and press **OK** to confirm.

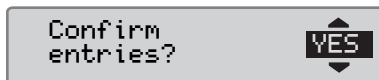

When "YES" is selected and the entries are saved the following display appears for a short time:

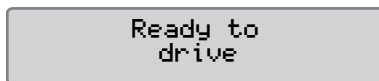

You are now ready to drive and the standard display will appear.



Modify Manual Entries

Clear all Entries

It is possible to clear the unsaved entries and restart the “Add manual entries” option.

To clear all entries, select and confirm “NO” when the “Confirm entries?” display appears.



1 Use the  or  to select “Clear all entries?”.

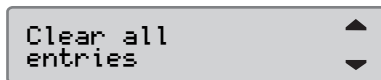

2 Press  again to confirm the clear all entries selection.

3 Press  again to clear all entries.

4 Use the  or  to select “YES” or “NO” and press .

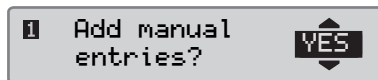

To restart the manual entries procedure, see

▷ Manual Entries Procedure, page 28

Journey with Ferry or Train

Ferry/Train Activity

To record that a ferry or train journey will take place, the “ferry/train” activity must be manually activated before starting the journey.



The “ferry/train” activity must not be confused with a mode. It is an activity with no endtime.

Activate Ferry/Train Activity

1 Press the **OK** button to show the tachograph menu.

▷ Tachograph Menu, page 17

2 Use the **▼** or **▲** buttons to select the “PLACES” menu and press **OK**.



3 Use the **▼** or **▲** buttons to highlight the “ferry/train” activity.

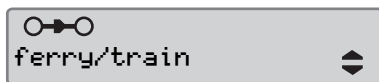

4 Press the **OK** button to activate the “ferry/train” activity.

Deactivate Ferry/Train Activity

The “ferry/train” activity will be deactivated automatically when the vehicle is set in motion.

Driving where no Recording is Required

Driving where no Recording is Required

Driving Out of Scope

There are driving conditions when recording is not required. This is the “**OUT of scope**” mode.

For detailed information, please see the EU tachograph regulations 561/2006 and national regulations.

!

It is the driver's responsibility to follow the driving regulations in the country concerned.

Activate Out of Scope Mode

1 Press the **OK** button to show the tachograph menu.

▷ Tachograph Menu, page 17

2 Use the **▼** or **▲** buttons to select the “**PLACES**” menu and press **OK**.

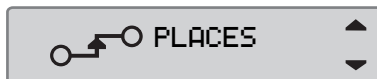

3 Use the **▼** or **▲** buttons to highlight the “**Out of scope**” activity.

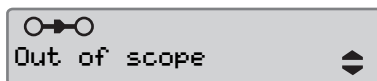

4 Press the **OK** button to activate the “**Out of scope**” activity. This is only visible in the standard display

▷ Standard Display, page 16

End out of scope

The “**Out of scope**” mode will be deactivated:

- Automatically when withdrawing or inserting a driver card.
- When manually entering the “**end out of scope**” mode.

Manually

1 Press the **OK** button to show the tachograph menu.

2 Use the **▼** or **▲** buttons to select the “**PLACES**” menu and press **OK**.



3 Use the **▼** or **▲** buttons to highlight the “**Out of scope**” activity.



4 Press the **OK** button to activate the “**End out of scope**” activity.

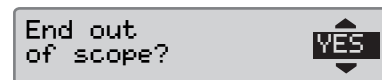

5 Press **OK** to confirm.

The current status is visible in the standard display.

Printouts

Create a printout

Data stored on the driver card and in the tachograph can be printed out in various printouts, see▷ Types of printout, page 42.



It is only possible to create a printout when the vehicle is stationary.



Keep the slot on the paper cassette unobstructed, otherwise there is a risk of a paper jam in the printer.

The data can be printed out on paper or shown in the display.

1 To create a printout from the print menu, press

2 Use the or buttons to select "PRINT". Confirm with .



3 Use the or buttons to select the wanted type of print out and press .

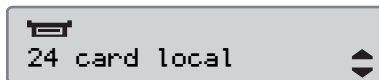

Select card and date

Depending on the chosen printout, it may be necessary to specify a driver card and date.

4 Use the or buttons to select card 1 or card 2 and press .

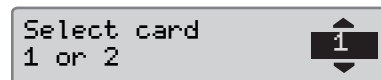



5 Use the or buttons to select desired date and press .





Printouts



Display Printout

- 1 Use the  or  buttons to select “display” and confirm with .



- 2 Use the  button to scroll through the displayed data.
- 3 Press  to return to the printout selection display.

Paper Printout

- 1 Use the  or  buttons to select “printer” and confirm with .

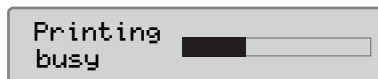

- 2 As soon as the “Printing busy” message is cleared, pull the printout upwards and tear it off.





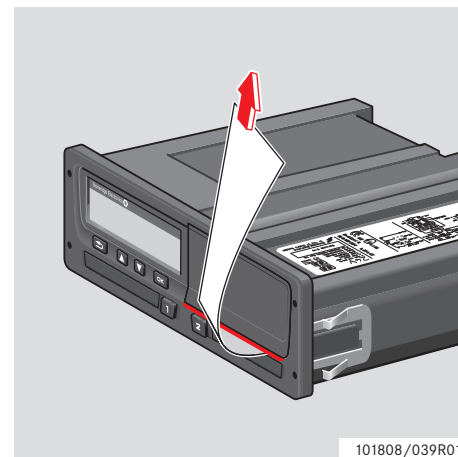









To cancel the ongoing printing process press and hold the  button (cancel).









101808/039R01





- ▶ Press  to return to the standard display.

Types of printout

Menu item	Type of printout	Description
 24h  ▼ 24h card 	Driver activities from card, daily printout. (legal requirement)	List of all activities for any of the dates with activities stored on the driver card or co-driver card in UTC-time.
 24h  ▼ 24h vehicle 	Driver activities from vehicle unit, daily printout. (legal requirement)	List of all activities stored in the tachograph for the selected date, in UTC time: <ul style="list-style-type: none"> • If no card is inserted, select either the current day or any of the eight recent days. • When a card is inserted, select any day stored in the tachograph, out of a maximum of typically the recent 28 days. If no data is available for the selected date, the printout will not be initiated.
 ! x  ▼ events card 	Events and faults printout from card. (legal requirement)	List of all warnings and malfunctions stored on a driver card.
 ! x  ▼ event vehicle 	Events and faults printout from vehicle unit. (legal requirement)	List of all warnings and malfunctions stored in the tachograph.

Printouts

Menu item	Type of printout	Description
 T 0 ▼ technical data ⚡	Technical data. (legal requirement)	List of the technical data in a tachograph.
 >> ▼ overspeeding ⚡	Over speeding printout. (legal requirement)	List of all overspeeding warnings.
 man entry sheet ⚡	Manual entries printout.	Printout for filling in manual entries manually using a pen.
 man entry confirmation ⚡	Manual entries printout.	Printout for manually entered activities in tachograph.
 vehicle speed ⚡	Vehicle speed (km/h).	List of vehicle speed bands in km/h.
 engine speed ⚡	Engine speed (rpm).	List of engine speed bands in rpm.
 status D1/D2 ⚡	Status rear connectors D1/D2.	List of changes in the status for rear connector D1 and D2. The output options for connectors D1 and D2 are company specific.

Menu item	Type of printout	Description
 24h card local 	Daily activities from driver card, in local time.	List of all activities for any of the dates with activities stored on the driver card, in local time.
 24h vehicle local 	Daily activities from the tachograph (VU), in local time.	List of all activities stored in the tachograph for the selected date, in local time: <ul style="list-style-type: none">• If no card is inserted, select either the current day or any of the eight recent days.• When a card is inserted, select any day stored in the tachograph, out of a maximum of typically the recent 28 days. If no data is available for the selected date, the printout will not be initiated.

Printouts

Printout Example**Daily printout (card)**

This example shows the printout for “Daily activities from the driver card”, in UTC time (**Print 24h card**).

The printout lists all activities stored on the driver card for a selected date in UTC time.

101808/061R02

- 1 Printout date and time (UTC time).
- 2 Type of printout (24h, card).
- 3 Card holder's surname.
- 4 Card holder's first name.
- 5 Card and country identification number.
- 6 Expiry date of the driver card.
- 7 Vehicle identification, VIN.
- 8 Registering member state and Vehicle Registration Number, VRN.
- 9 Tachograph manufacturer.
- 10 Tachograph part number.
- 11 Responsible workshop for last calibration.
- 12 Workshop card number.
- 13 Date of last calibration.
- 14 Last control the inspected driver has been subjected to.

(Continuing on next page) ▷▷

101808/053R03

15 06/03/2009 52

16 -----1-----

17 A S /ABC 123

18 0 km

19 X 00:00 08:53 08h53 @@
H 08:53 08:55 00h02

-----1-----

20 A S /ABC 123
X 08:55 08:56 00h01 @@
@ 08:56 08:57 00h01 @@
@ 08:57 10:22 01h25 @@
@ 10:22 10:23 00h01 @@
H 10:23 10:32 00h09 @@

21 1 km; 1 km

-----Σ-----

22 ▶● 08:53 S
0 km
@ 00h02 1 km
X 08h54 @ 01h25
@ 00h11 ? 00h00
@ 10h30

- 15 Enquiry date and daily card presence counter.
- 16 Driver card in card tray 1.
- 17 VRN, Vehicle Registration Number, for the vehicle where the driver card is insert.
- 18 Vehicle odometer at card insertion.
- 19 Activity while card was inserted.
- 20 Activities with driver card inserted.
- 21 Card withdrawal: Vehicle odometer and distance travelled since last insertion for which odometer is known.
- 22 Daily summary of activities, begin and end details (time, place and odometer).

(Continuing on next page) ▷▷

Printouts

-----!X#-----

!# 27/02/2009 16:32
!11 93h41
S /ABC 123

-----!X#-----

X# 05/03/2009 15:20
X35 17h32
S /ABC 123

-----!X#-----

!# 05/03/2009 15:20
!11 17h32
S /ABC 123

-----!X#-----

X# 06/03/2009 08:55
X35 01h37
S /ABC 123

-----!X#-----

!# 06/03/2009 08:55
!11 01h37
S /ABC 123

-----!X#-----

X# 00 03/03/2009 09:15
X35 05h10
#

-----!X#-----

!# 00 03/03/2009 09:15
!11 05h10
#

-----!X#-----

!# 01 03/03/2009 14:26
!08 (1) 48h53
#

-----!X#-----

X# 07 05/03/2009 15:20
X35 19h12
#S /00007001106910 0 0
#S /00007001106880 0 0

-----!X#-----

!# 07 05/03/2009 15:20
!11 19h12
#S /00007001106910 0 0
#S /00007001106880 0 0

101808/102R02

25 [icon]

26 [icon]

27 [icon]

101808/062R02

- 23** Last five events and faults from the driver card.
- 24** Last five events and faults from the VU, vehicle unit.
- 25** Control place.
- 26** Controller's signature.
- 27** Driver's signature.

Daily printout (VU)

This example shows the printout for

“Daily activities from the vehicle”, in UTC time” (Print 24h VU).

The printout lists all activities stored on the vehicle unit for a selected date in UTC time.

Note! For excluded parts, see the driver card print out.

Stoneridge

1 06/03/2009 10:39 (UTC)

2 24h VU

3 Andersson

4 Richard

5 S /00007001106910 0 0

6 20/02/2012

7 Schmidt

8 Magnus

9 S /00007001106880 0 0

10 20/02/2012

11

12 06/03/2009

13 0 - 1 km

14 Andersson
Richard
S /00007001106910 0 0
20/02/2012

101808/063R02

- 1 Printout date and time (UTC time).
- 2 Type of printout (24h, VU).
- 3 Card holder's surname (driver).
- 4 Card holder's first name (driver).
- 5 Card and country identification number.
- 6 Expiry date of the driver card.
- 7 Card holder's surname (co-driver).
- 8 Card holder's first name (co-driver).
- 9 Card and country identification number.
- 10 Expiry date of the co-driver card.
- 11 Drivers activities stored in the VU per slot in chronological order.
- 12 Enquiry date.
- 13 Vehicle odometer at 00:00 and 24:00.
- 14 Driver

(Continuing on next page) >>

Printouts

15 A → S /ABC 123
 16 03/03/2009 11:45
 17 0 km
 18 ✕ 00:00 08:53 08h53 0 0
 0 km;
 0 km

 0 km
 ✕ 08:53 08:55 00h02 0 0
 0 km;
 0 km

 Andersson
 Richard
 S /00007001106910 0 0
 20/02/2012
 A → S /ABC 123
 06/03/2009 10:26
 0 km
 ✕ 08:55 08:56 00h01 0 0
 08:56 08:57 00h01 0 0
 08:57 10:22 01h25 0 0
 10:22 10:23 00h01 0 0
 10:23 10:39 00h16 0 0
 1 km;
 1 km

 19 Schmidt
 Magnus
 S /00007001106880 0 0
 20/02/2012
 A → S /ABC 123
 21 05/03/2009 14:40
 0 km
 22 00:00 08:53 08h53 0 0
 0 km;
 0 km

 0 km
 23 08:53 08:55 00h02 0 0
 0 km;
 0 km

101808/113R02

- 15 Registration member state and vehicle registration number of previous vehicle used.
- 16 Date and time of card withdrawal from previous vehicle.
- 17 Vehicle odometer at card insertion.
- 18 Activities with start and end time.
- 19 Co-driver.
- 20 Registration member state and vehicle registration number of previous vehicle used.
- 21 Date and time of card withdrawal from previous vehicle.
- 22 Vehicle odometer at card insertion.
- 23 Activities with start and end time.

(Continuing on next page) ▷▷

```

    ☐ Schmidt
      Magnus
    ☐S /00007001106880 0 0
      20/02/2012
    A → S /ABC 123
      06/03/2009 10:25
              0 km      M
    ☐ 08:55 08:56 00h01 ☐☐
    H 08:56 10:39 01h43 ☐☐ *
              1 km;      1 km
    -----Σ-----
1|☐---
    ☐ 00h00      0 km
    X 00h02 ☐ 00h00
    H 00h00
2|☐---
    X 00h00 ☐ 00h02
    H 00h00
    -----
    ☐ Andersson
      Richard
    ☐S /00007001106910 0 0
    ►●08:53 S
              0 km      1km
    ☐ 00h02      ☐ 01h25
    X 08h54
    H 00h16
    ☐☐10h37
    -----
    ☐ Schmidt
      Magnus
    ☐S /00007001106880 0 0
    ►●08:53 S
              0 km      1km
    ☐ 00h00      ☐ 08h54
    X 00h00
    H 01h43
    ☐☐10h37
  
```

01808/114R02

M= Manual entries of driver activities.

* = Rest period of at least one hour.

- 24** Summary of periods without card in driver slot.
- 25** Summary of periods without card in co-driver slot.
- 26** Daily summary of activities, begin and end details (time, place and odometer) (driver).
- 27** Daily summary of activities, begin and end details (time, place and odometer) (co-driver).

Printouts

Events and faults (card)

This example shows the printout for “Event and fault”, in UTC time, (**event card**).

This printout shows all events and fault stored on a driver card.

Stoneridge

1 20/07/2007 09:48 (UTC)

2 !X

3 Andersson

4 Richard

5 S /ABCD6789012345 1 1

6 31/12/2012

7 1234567890ABCDEFG
S /123 A 23F

8 24/1/2007 07:30
00h05
1234567890ABCDEFG
S /123 A 23F

3/2/2007 15:30
00h00
1234567890ABCDEFG
VIN
S /123 A 23F

101808/106R01

- 1 Date and time (UTC time).
- 2 Type of printout. (event and faults, card).
- 3 Card holder’s surname.
- 4 Card holder’s first name.
- 5 Card and country identification number.
- 6 Expiry date of the driver card.
- 7 Vehicle identification. VIN, registering member state and VRN.
- 8 List of all events stored on the card.

(Continuing on next page) >>

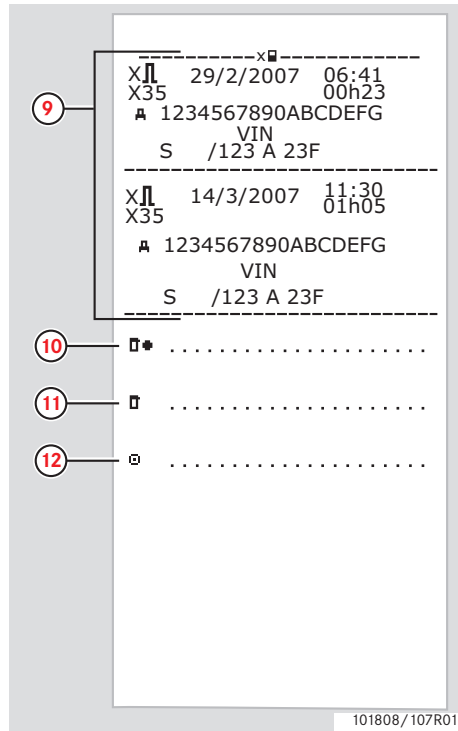

- 9 List of all faults stored on the card.
- 10 Control place.
- 11 Controller's signature.
- 12 Driver's signature.

Printouts

Events and faults (VU)

This example shows the printout for “Event and fault, Vehicle Unit”, in UTC time,” (event vu).

This printout shows all events and fault stored in a Vehicle Unit.

Stoneridge

1 20/07/2007 09:48 (UTC)

2 !XAV

3 Andersson

4 Richard

5 S /ABCD6789012345 1 1

6 31/12/2012

7 1234567890ABCDEFG
S /123 A 23F

8

!02	07/02/2007	06:24
!04	(10)	00h00
A	1234567890ABCDEFG	
S	/123 A 23F	
!05	07/02/2107	06:24
!08	(10)	00h00
A	1234567890ABCDEFG	
S	/123 A 23F	

101808/108R01

- 1 Date and time (UTC time).
- 2 Type of printout. (event and faults, VU).
- 3 Card holder’s surname.
- 4 Card holder’s first name.
- 5 Card and country identification number.
- 6 Expiry date of the driver card.
- 7 Vehicle identification. VIN, registering member state and VRN.
- 8 List of all events stored in the VU.

(Continuing on next page) >>

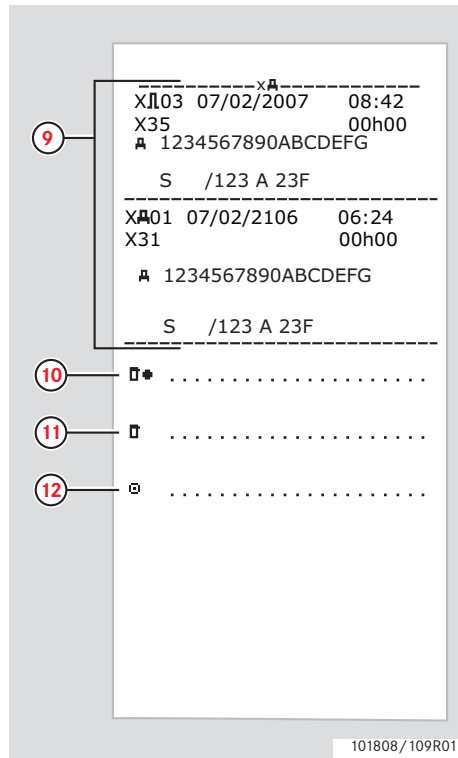

- 9 List of all faults stored in the VU.
- 10 Control place.
- 11 Controller's signature.
- 12 Driver's signature.

Printouts

Technical data

This example shows the printout for “Technical data, in UTC time,” (**technical data**).

This printout lists data such as speed settings, tyre size, calibration data and time adjustments.

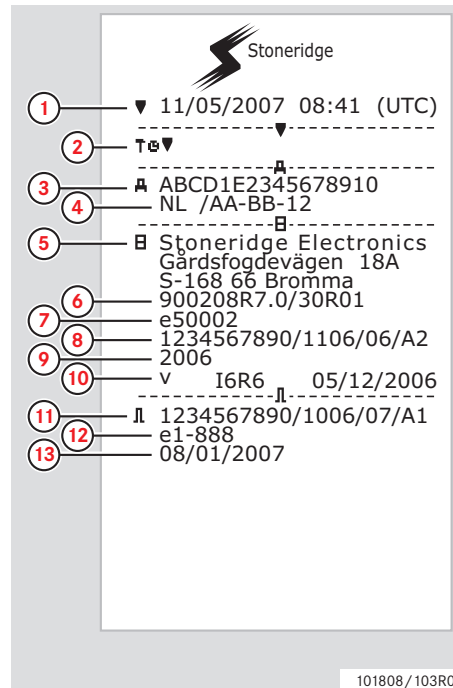

- 1 Date and time (UTC time).
- 2 Type of printout. (technical data).
- 3 Vehicle Identification Number (VIN).
- 4 Vehicle Registration Number (VRN) and country of registration.
- 5 Tachograph manufacturer.
- 6 Tachograph part number.
- 7 Tachograph approval number.
- 8 Tachograph serial number, date of manufacture, type of equipment and code of manufacturer.
- 9 Year of manufacture.
- 10 Software version and installation date.
- 11 Motion sensor serial number.
- 12 Motion sensor approval number.
- 13 Date of first installation of motion sensor.

(Continuing on next page) ▷▷

-----T-----
 14 T STONERIDGE ELECTRONICS
 15 168 66 BROMMA
 16 T S /12345678901012 1 0
 17 21/10/2007
 18 T 08/01/2007 (1)
 19 A NL /AA-BB-12
 20 /?????????????
 21 w 9 150 Imp/km
 22 k 9 150 Imp/km
 23 l 3 331 mm
 24 * 315/80 R22.5
 25 > 89 km/h
 26 15 km; 15 km

 T Johansson and Sons
 123 45 BROMMA
 T S /12345678901012 1 0
 21/10/2007
 27 T 09/01/2007 (2)
 28 A ABCD1E2345678910
 29 NL /AA-BB-12
 w 9 150 Imp/km
 k 9 150 Imp/km
 l 3 331 mm
 * 315/80R22.5
 > 89 km/h
 0 km; 26 km

101808/104R01

- 14 Workshop having performed the calibration.
- 15 Workshop address.
- 16 Workshop card identification.
- 17 Workshop card expiry date.
- 18 Calibration date.
- 19 VIN
- 20 VRN and country of registration.
- 21 Characteristic coefficient of vehicle.
- 22 Constant of the recording equipment.
- 23 Effective circumference of wheel tyres.
- 24 Vehicle tyre size.
- 25 Authorized speed setting.
- 26 Old and new odometer values.
- 27 Calibration date and purpose.
- 28 VIN.
- 29 VRN and country of registration.

(Continuing on next page) ▷▷

Printouts

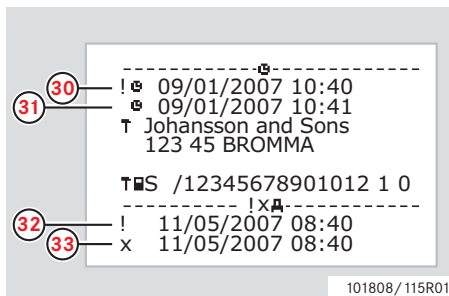

- 30** Old date and time. (Before time adjustment)
- 31** New date and time. (After timeadjustment)
- 32** Most recent event time.
- 33** Most recent fault date time.

Overspeeding

This example shows the printout for “Overspeeding,” (**overspeeding**).

This printout lists overspeeding events, the duration of the overspeeding event and the driver.

The printout also lists the five most serious overspeeding events over the last 365 and the most serious events for each of the ten last days.

Stoneridge

1 20/07/2007 09:48 (UTC)

2 >>> ▼

3 Andersson

4 Richard

5 S /ABCD6789012345 1 1

6 31/12/2012

7 A 1234567890ABCDEFGH
S /123 A 23F

8 >> 9/2/2007 11:31
>> 17/1/2007 (008)

9 >>> T
>> 12/2/2007 19:24 00h05
98 km/h 94 km/h (1)

Andersson
Richard

S /ABCD6789012345 1 1
31/12/2012

101808 / 105R01

- 1 Date and time (UTC time).
- 2 Type of printout. (overspeeding).
Speed limiting device setting.
- 3 Card holder’s surname.
- 4 Card holder’s first name.
- 5 Card and country identification
number.
- 6 Expiry date of the driver card.
- 7 Vehicle identification. VIN, register-
ing member state and VRN.
- 8 Date and time of the last overspeed-
ing control.
Date and time of first overspeeding
and number of overspeeding events
- 9 First overspeeding after the last cali-
bration.
Date time and duration.
Max and average speed.
Driver and drivers card
identification.

(Continuing on next page) >>

Printouts

The printout shows a list of speed camera events. Callout 10 points to the first event, callout 11 to the next two events, callout 12 to a signature field, callout 13 to another signature field, and callout 14 to a third signature field.

```

----->>(365)-----
>>9/2/2007 11:31 00h10
99 km/h 97 km/h
  ▣ Svensson
    Bertil
  ▣ S /EFGH123456786 2 2

----->>10-----
>>12/2/2007 19:24 00h05
98 km/h 94 km/h (1)
  ▣ Andersson
    Richard
  ▣ S /ABCD6789012345 1 1

>>12/2/2007 19:24 00h10
99 km/h 97 km/h (1)
  ▣ Svensson
    Bertil
  ▣ S /EFGH123456786 2 2

-----
  ▣* .....
  ▣ .....
  ▣ .....
  
```

101808/110R01

- 10** Five most serious overspeeding over the last 365 days.
Date time and duration.
Max and average speed.
Driver and drivers card identification.
- 11** Most serious overspeeding events over the last ten days.
Date time and duration.
Max and average speed.
Driver and drivers card identification.
- 12** Control place.
- 13** Controller's signature.
- 14** Driver's signature.

Vehicle speed

This example shows the printout for “Vehicle speed,” (**vehicle speed**).

This printout lists the speed in speed bands of the vehicle in chronological order of drivers.

Stoneridge

1 20/07/2007 09:48 (UTC)

2 KM/H

3 Andersson

4 Richard

5 S /ABCD6789012345 1 1

6 31/12/2012

7 A 1234567890ABCDEFGG
S /123 A 23F

8 S / B D 7 9 1 3 5 1
31/12/2012

9 11/07/2007 06:36

10 11/07/2007 19:24

11

----- KM/H -----	
0 <= v < 10	00h06
10 <= v < 20	00h08
20 <= v < 30	00h07
30 <= v < 40	01h06
40 <= v < 50	01h06
50 <= v < 60	01h06
60 <= v < 70	01h06
70 <= v < ...	01h06

101808/116R01

- 1 Date and time (UTC time).
- 2 Type of printout. (vehicle speed).
- 3 Card holder’s surname.
- 4 Card holder’s first name.
- 5 Card and country identification number.
- 6 Expiry date of the driver card.
- 7 Vehicle identification. VIN, registering member state and VRN.
- 8 Information about previous driver (In chronological order).
- 9 Previous drivers start date and time.
- 10 Previous drivers end date and time.
- 11 Speed band and duration time.

(Continuing on next page) ▷▷

Printouts

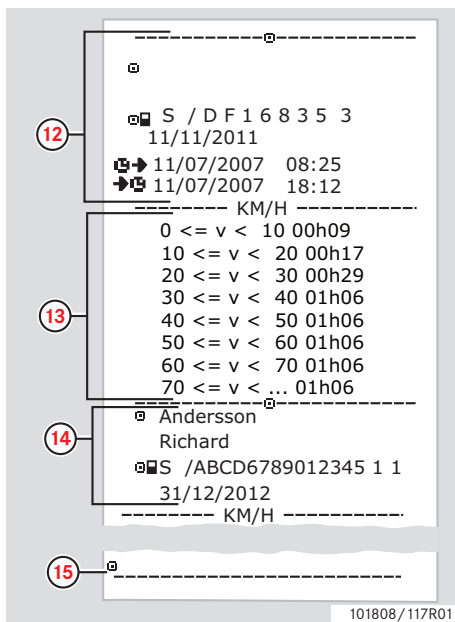

- 12 Information about previous driver (In chronological order).
- 13 Speed band and duration time.
- 14 Latest driver card information.
- 15 Driver's signature.

Engine speed (rpm)

This example shows the printout for “Engine speed,” (engine speed). This printout lists the vehicles engine speed in bands of rpm in chronological order of drivers.

Stoneridge

1 20/07/2007 09:48 (UTC)

2 RPM

3 Andersson

4 Richard

5 S / ABCD6789012345 1 1

6 31/12/2012

7 1234567890 ABCDEFG
S /123 A 23F

8 S / B D 7 9 1 3 5 1
31/12/2012

9 11/07/2007 06:36

10 11/07/2007 19:24

11 RPM

0 <= n < 100 01h06

100 <= n < 200 01h06

200 <= n < 300 01h06

300 <= n < 400 01h06

400 <= n < 500 01h06

500 <= n < 600 01h06

600 <= n < 700 01h06

700 <= n < 800 01h06

800 <= n < 01h06

101808/118R01

- 1 Date and time (UTC time).
- 2 Type of printout. (engine speed).
- 3 Card holder’s surname.
- 4 Card holder’s first name.
- 5 Card and country identification number.
- 6 Expiry date of the driver card.
- 7 Vehicle identification. VIN, registering membership state and VRN.
- 8 Information about previous driver (In chronological order).
- 9 Previous drivers start date and time.
- 10 Previous drivers end date and time.
- 11 Speed band of engine and duration time.

(Continuing on next page) ▷▷

Printouts

The printout shows a driver's license application form with the following fields and callouts:

- 12** Points to the driver's name and date of birth: S / D F 1 6 8 3 5 3, 11/11/2011.
- 13** Points to the speed band of engine and duration time table:

RPM	
0 <= n < 100	01h06
100 <= n < 200	01h06
200 <= n < 300	01h06
300 <= n < 400	01h06
400 <= n < 500	01h06
500 <= n < 600	01h06
600 <= n < 700	01h06
700 <= n < 800	01h06
800 <= n <	01h06

- 14** Points to the latest driver card information: Andersson, Richard, S / ABCD6789012345 1 1, 31/12/2012.
- 15** Points to the driver's signature field.

At the bottom of the printout, the text "101808/119R01" is visible.

- 12** Information about previous driver (In chronological order).
- 13** Speed band of engine and duration time.
- 14** Latest driver card information.
- 15** Driver's signature.

Status D1/D2

This example shows the printout for “Status D1/D2,” (**status D1/D2**).

This printout lists the changes of status of the rear connectors.

The output of the rear connectors are company specific.

Stoneridge

1 20/07/2007 09:48 (UTC)

2 STATUS 1/2

3 Andersson

4 Richard

5 S /ABCD6789012345 1 1

6 31/12/2012

7 A 1234567890ABCDEFG
S /123 A_23F

8 15/07/2007
STATUS 1/2

STATUS	D1	D2	TIME
1	0		
0	0		00:00:48
0	1		00:01:36
1	0		00:04:48
0	1		00:08:48
1	1		00:13:52
0	1		00:17:36
1	0		00:21:36
1	1		00:25:52

10

101808/120R01

- 1 Date and time (UTC time).
- 2 Type of printout. (Status D1/D2).
- 3 Card holder’s surname.
- 4 Card holder’s first name.
- 5 Card and country identification number.
- 6 Expiry date of the driver card.
- 7 Vehicle identification. VIN, registering member state and VRN.
- 8 Selected date of printout.
- 9 Changes of status and duration time for the connectors.
- 10 Driver’s signature.

Printouts

Printouts in local time

It is possible to make printouts for 24h card and 24h VU in local time.

These printouts makes it easy to check activities such as end and start time in local time.

The printouts contains the same information as the ones printed in UTC time, with the difference that the time is displaced.



** OUT OF REGULATION ** states that this printout is not compliant with any regulations.

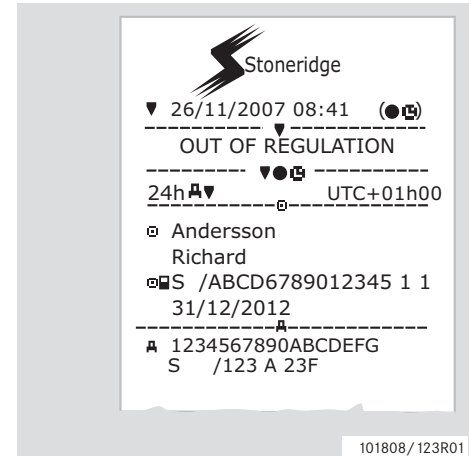
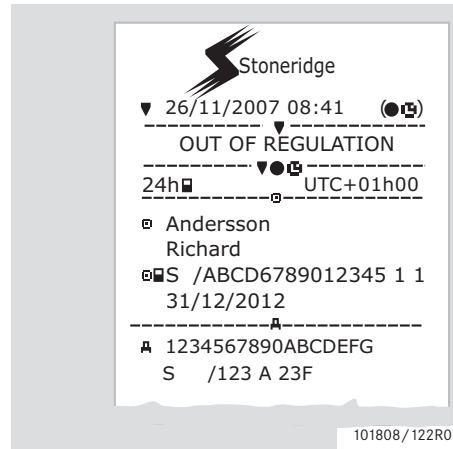

Printout, Manual Entries Confirmation

This is the printout from the Manual Entries Confirmation Scenario.

(▷ Manual Entries Scenarios, page 27)

Stoneridge

1 26/11/2007 08:41 (●●)

2 MO? UTC+01h00

3 1234567890ABCDEF
S /123 A 23F

4 23/11/07 15:23

5

✕	15:23	18:00	02h37
⌂	18:00	08:00	62h00
☑	08:00	08:37	00h37

6 26/11/07 08:37

7

✕	02h37	☑	00h37
⌂	62h00	?	00:00
Σ	65h14		

101808/121R02

- 1 Date and time (local time).
- 2 Type of printout (Manual Entries).
- 3 Vehicle identification. VIN, registering member state and VRN.
- 4 Card redrawing time.
- 5 Manual entries with duration time.
- 6 Card insertion time.
- 7 Summary of manual entries.

Printouts

Printout, Manual Entry Sheet

Printout sheet for filling in manual entries with a pen.

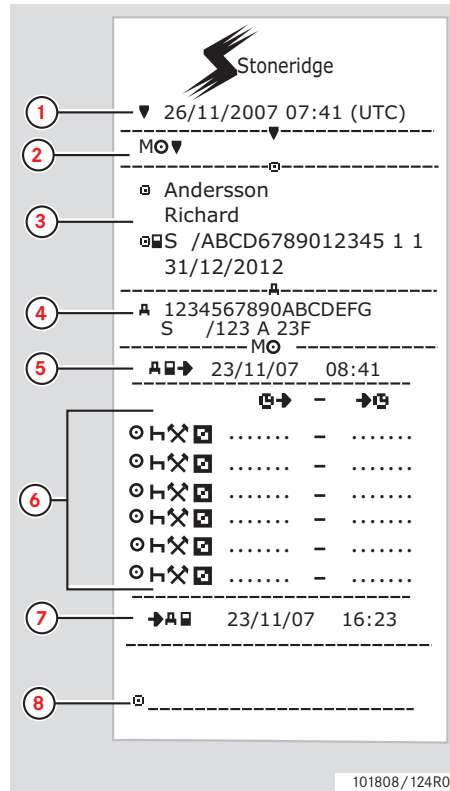

- 1 Date and time (UTC time).
- 2 Type of printout (Manual Entry Sheet).
- 3 Card holder identification.
- 4 Vehicle identification.
- 5 Card redrawal time.
- 6 Manual entries with duration time.
- 7 Card insertion time.
- 8 Driver's signature.

Settings

Settings

The following settings can be changed:

- Tachograph language.
- Local time.
- UTC time.
- Invert display.
- Built-in test.

▷ Built-in Test, page 98



It is only possible to change settings when the vehicle is stationary.

Language

The driver card language is by default used in the tachograph and on the printouts.

The tachograph and the printouts can be changed to one out of 24 languages.

(▷ Available Languages, page 108)



The chosen language is saved only in the tachograph, not on the driver card.

- 1 Press the button.
- 2 Use the or button to select “SETTINGS” and press .



- 3 Use the or button to select “Language” and press .

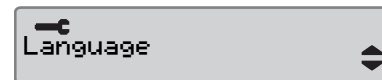

- 4 Use the or button to select the desired language and press .



- 5 The following display appears for a short time:

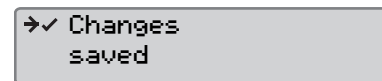

The setting is saved.

Press twice to return to the standard display.

Settings

Change UTC Time

All activities recorded by the tachograph is always using UTCtime, Universal Time Co-ordinated:

- UTC time more or less corresponds to Greenwich Mean Time (GMT).
- The UTC time is not adjusted for summer/winter time.



- The UTC time can be adjusted by a maximum of +/-1 minute per week in the operational mode of operation.
- The UTC time cannot be set closer than one hour before the driver card's expiry time.



If the UTC time in the tachograph has deviated by more than 20 minutes, the tachograph must be calibrated by a digital tachograph workshop.

- 1 Press the **OK** button.
- 2 Use the **▼** or **▲** button to select "SETTINGS" and press **OK**.



- 3 Use the **▼** or **▲** button to select "UTC time" and press **OK**.

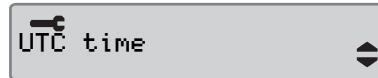

- 4 Use the **▼** or **▲** button to change the UTC time one minute and press **OK**.

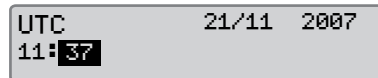

- 5 The following display appears for a short time:

A rectangular display box with a grey background. It shows the text "→✓ Changes saved" in the center.

The setting is saved.

Press **↵** twice to return to the standard display.

Change Local Time

Local time is the current time in a specific country. Local time is set manually.

Local time is only shown as information:

- On the driver standard display.
- At manual entries of activities.
- On a few printouts.



The local time can be adjusted in steps of 30 minutes.

- 1 Press the **OK** button.
- 2 Use the **▼** or **▲** button to select "SETTINGS" and press **OK**.

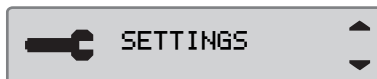

- 3 Use the **▼** or **▲** button to select "Local time" and press **OK**.

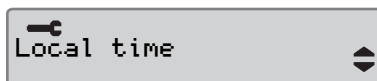

- 4 Use the **▼** or **▲** button to change the UTC time one minute and press **OK**.

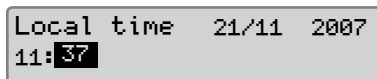

- 5 The following display appears for a short time:

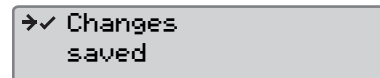

The setting is saved.

Press **ESC** twice to return to the standard display.

Daylight Saving Time

An automatic local time adjustment for summer and winter is automatically prompted on the last Sunday in March and last Sunday in October, respectively. Select "YES" to acknowledge or "NO" to cancel time change.

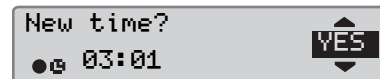

Settings

Invert Display

The display can be set in either of the following appearance modes:

- Positive view.
- Inverted view.

To change the appearance:

1 Press the **OK** button.

2 Use the **▼** or **▲** button to select “SETTINGS” and press **OK**.



3 Use the **▼** or **▲** button to select “Local time” and press **OK**.

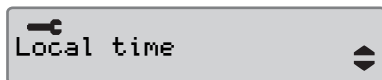

4 Use the **▼** or **▲** button to change the UTC time one minute and press **OK**.



5 The following display appears for a short time:

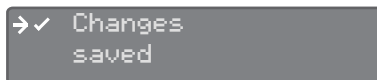

The setting is saved.

Press **↵** twice to return to the standard display.



Driver Displays

Symbols

Messages, Warnings and Malfunctions

Displays

Driver Displays

- ▶ Use the  or  button to select to scroll up or down to show one of the following displays.

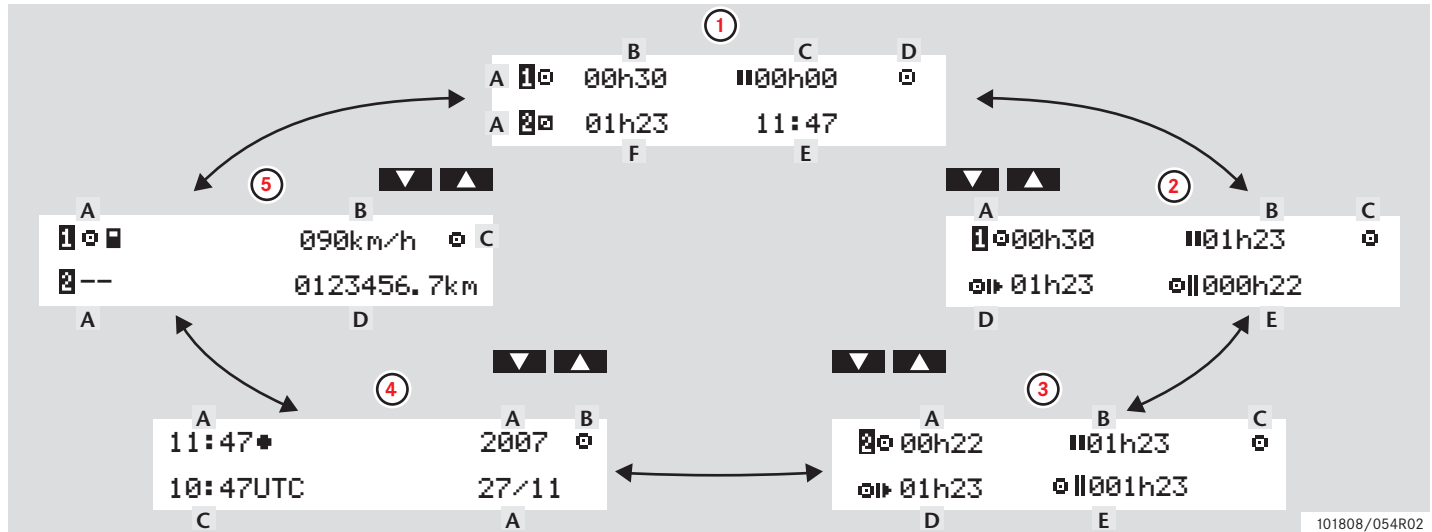

Displays

	Display type	Information	
1	Standard display, driver 1 and 2	A. Current activity, driver 1 & 2 B. Continuous drive time, driver 1 C. Cumulative break time, driver 1	D. Mode of operation E. Local time F. Duration of activity, driver 2
2	Driver 1	A. Continuous drive time B. Cumulative break time C. Mode of operation	D. Cumulative driving time current day E. Cumulative driving time last 14 days
3	Driver 2	A. Continuous drive time B. Cumulative break time C. Mode of operation	D. Cumulative driving time current day E. Cumulative driving time last 14 days
4	Date and time	A. Local time and date B. Mode of operation	C. UTC time
5	Current speed display	A. Type of card inserted in tray 1 & 2 B. Current speed	C. Mode of operation D. Odometer

!

The displayed driving and rest times should only be used as indicative data, with respect to the current social legislation in a certain country. Please check and calculate with help of relevant 24h card printouts if in doubt.

Symbols

Symbols









The symbols shown in the display and on the printouts represent persons, activities or processes. (▷ Symbol Combinations, page 78)









Symbol	Description
⊖	Function not available
1, 1	Driver slot
2, 2	Co-driver slot
■	Card
▲	Eject
✕	Work
○	Driving/driver
⌂	Rest/break
☑	Available
⚓	Ferry/train crossing
OUT	“Out of scope”, i.e. no recording is required

Symbol	Description
●	Local time/location
▶	Start of daily work period
◀	End of daily work period
	Break
→	From or to
▼	Printer, printout
ℙ	Paper
□	Display
⌘	Processing, please wait
⌚	Time, clock

Symbol	Description
UTC	UTC time
24h	Daily
	Weekly
	Two weeks
Σ	Total/summary
>	Speed
>>	Over speeding
✕	Faults
!	Events
?	Question/unknown

Symbols

Symbol	Description
	Workshop
	Company
	Controller
	Manufacturer
	Security
	External storage/download
	Buttons
	Finished
	Tachograph (VU), vehicle

Symbol	Description
	Tyre size
	Sensor
	Power supply
	Print
	Print, submenu
	Company lock
	Places
	Places, sub menu
	Settings

Symbol Combinations

The symbol combinations shown in the display and on the printouts represent persons, activities or processes.

Combination	Description
● ▶	Location start of daily work period
▶ ●	Location end of daily work period
🕒 →	From time (UTC)
→ 🕒	To time (UTC)
● 🕒	Local time
○ ○	Crew driving
○	Driving time for two weeks
OUT →	“Out of scope” begin
→ OUT	“Out of scope” end
○ ▶	Cumulative driving time of current day

Combination	Description
↓ ○	Printer low temperature
↑ ○	Printer high temperature
🗑️ --	No card
○ 🗑️	Driver card
🔧 🗑️	Workshop card
🏢 🗑️	Company card
🔧 🗑️	Control card
🔧 ●	Control place
🚗 →	From vehicle

Messages, Warnings and Malfunctions

Messages, Warnings and Malfunctions

Three Types of Notifications

The information shown on the tachograph display is separated into three types of notifications, depending on the seriousness of a specific occurrence:

- Messages
- Warnings
- Malfunctions

An alphabetical list of all driver related messages, warnings and malfunctions is presented on the following pages.

In this list “Driver Card” is shortened to “Card”.

Messages

Messages are information about completed processes, problems with the driver card or a reminder to take a break.

Messages are not stored and cannot be printed out.

▶ Press the **OK** button to clear a message.

Warnings

Warnings appear in the event of law infringements, such as overspeeding, or if tachograph data cannot be recorded for various reasons.

Warnings appears either as a pop up or as a flash in the display.

Warnings are stored and can be printed out.

▷ Create a printout, page 40

Press the **OK** button twice to clear a warning.

Malfunctions

Malfunctions are more critical than warnings. They are displayed in case of a tachograph, a sensor or a driver card malfunction or if tampering with this equipment are detected.





Malfunctions are stored and can be printed out.

▷ Create a printout, page 40

Press the **OK** button to acknowledge a warning.

Displays and Data

Messages, Warnings and Malfunctions







Display	Type	Unit	Description	Action
	Message	Tachograph	Entry not possible while driving.	▶ Stop the vehicle and try the entry again.
!  Already in company mode	Malfunction	Card	Two company cards inserted. The second card will be ejected without being authenticated.	▶ Insert only one Company card.
!  Already in control mode	Malfunction	Card	Two control cards inserted. The second card will be ejected without being authenticated.	▶ Insert only one Control card.
!  Already in calibration mode	Malfunction	Card	Two workshop cards inserted. The second card will be ejected without being authenticated.	

Messages, Warnings and Malfunctions

Display	Type	Unit	Description	Action
× 1 Card 1 fault	Malfunction	Card	The card in tray 1 (“2” if tray 2) is defective.	<ul style="list-style-type: none"> ▶ Eject the card and check it visually. ▶ Clean the card with a soft damp cloth and try again. ▶ If the display is still shown, perform a self test (▷ Built-in Test, page 98). ▶ If the fault remains, visit a digital tachograph workshop to have the equipment checked.
! 1 Card 1 time overlap	Warning	Tachograph	The last withdrawal time of the inserted driver card is later than the date/time of the VU.	<ul style="list-style-type: none"> ▶ Withdraw the driver card. ▶ Check the date/time of the VU and change if necessary. ▶ Wait for the overlap period to elapse.
! 1 Card auth. failure	Malfunction	Card	The tachograph security check for the card in tray 1 (“2” if tray 2) failed.	<ul style="list-style-type: none"> ▶ Eject the card and check it visually. ▶ Clean the card with a soft damp cloth and try again. ▶ If the display is still shown, perform a self test (▷ Built-in Test, page 98).
! 1 Card conflict	Warning	Card	An invalid card combination has been detected.	<ul style="list-style-type: none"> ▶ Withdraw the offending card.

Displays and Data

Messages, Warnings and Malfunctions

Display	Type	Unit	Description	Action
  1 Card data integrity error	Malfunction	Card	Corrupt data detected when reading data from the card in tray 1 (“2” if tray 2) to the tachograph.	<ul style="list-style-type: none">▶ Eject the card and check it visually.▶ Clean the card with a soft damp cloth and try again.▶ If the malfunction remains, perform a self test (▷ Built-in Test, page 98).▶ If the fault remains, visit a digital tachograph workshop to have the equipment checked.
  x1 Card eject without saving	Message	Card	Data could not be stored on the card withdrawn from tray 1 (“2” if tray 2) due to an error.	<ul style="list-style-type: none">▶ Clean the card with a soft damp cloth and try again.▶ If the display is still shown, perform a self test (▷ Built-in Test, page 98).▶ If the fault remains, visit a digital tachograph workshop to have the equipment checked.
  1 Card expired	Message	Card	The card in tray 1 (“2” if tray 2) has expired.	<ul style="list-style-type: none">▶ Remove the card and replace it with a valid one.

Messages, Warnings and Malfunctions



Display	Type	Unit	Description	Action
1 Card expires in xx days	Warning	Card	The card inserted in tray 1 (“2” if tray 2) expires in xx days, where xx is a number between 0 and 30.	▶ Contact the responsible authority to get a new card. The message disappears automatically after 5 seconds or when a button is pressed.
! Card ins. while driving	Warning	Card	A driver card was inserted while the vehicle was in motion.	▶ Continue the journey if the driver card is valid.
→ ✓ Changes saved	Message	Tachograph	A pop-up message to confirm that a change is saved.	▶ No further action required.
! A/A Data integrity error	Malfunction	Tachograph	The user data stored in the tachograph has errors.	▶ Visit a digital tachograph workshop to have the equipment checked.
↓ × ↓ Download failed	Malfunction	Tachograph	A failure when trying to download data from the tachograph.	▶ Retry the download. ▶ Visit a digital tachograph workshop to have the equipment checked.
↓ ✓ ↓ Download complete	Message	Tachograph	The tachograph download process has been completed successfully.	▶ No further action required.
○ 1/2 * Driving can't open slot	Message	Tachograph	An attempt was made to open the slot while the vehicle was in motion.	▶ Stop the vehicle. The card tray can be opened only when the vehicle is stationary.

Displays and Data

Messages, Warnings and Malfunctions

Display	Type	Unit	Description	Action
! ◯ ■ Driving w/o valid card	Warning	Card	Driving without an appropriate card, or with an inappropriate card combination.	▶ Stop and remove inappropriate card.
fn * Function not possible	Message	Tachograph	The desired function cannot be carried out.	▶ Check if the tachograph is set in the correct mode of operation. ▶ If the display still shows, visit a digital tachograph workshop to have the equipment checked.
! Ⓜ A Hardware sabotage	Malfunction	Tachograph	Card has been removed by force or a tampering with the hardware has been detected.	▶ Visit a digital tachograph workshop to have the equipment checked.
! ■ Insertion of a non valid card	Warning	Card	A non-valid card has been inserted to a slot.	▶ Withdraw the non-valid card.
! ■ A1 Last sess. not closed ok	Warning	Card	The driver card in tray 1 (“2” if tray 2) was ejected incorrectly during the last session. The previous card withdrawal in tray 1 (“2” if tray 2) was not completed correctly by the tachograph.	▶ Eject the card and check it visually. ▶ Clean the card with a soft damp cloth and try again. ▶ If the display is still shown, perform a self test (▷ Built-in Test, page 98).

Messages, Warnings and Malfunctions



Display	Type	Unit	Description	Action
⌘ → ✓ Lock-in complete	Message	Tachograph	The lock-in is completed.	▶ No further action required.
← ⌘ ✓ Lock-out complete	Message	Tachograph	The lock-out is completed.	▶ No further action required.
M.....! Memory full!	Message	Tachograph	Manual entries memory full.	▶ Modify the manual entries so that the total number of entries is less.
New time? ● 03:01 	Message	Tachograph	Daylight saving time changes.	▶ Answer “YES” to start or end daylight saving time. ▶ Answer “NO” or press the  button to cancel.
! ◯ / T ■ No driver/ workshop card	Message	Card	A function has been selected that requires an inserted driver or workshop card.	▶ Insert a driver card. ▶ Visit a digital tachograph workshop to have the equipment checked.
! ■ ? No further details	Mal-function	Sensor	An unknown type of sensor error occurred.	▶ Visit a digital tachograph workshop to have the equipment checked.

Displays and Data

Messages, Warnings and Malfunctions

Display	Type	Unit	Description	Action
>> Over speeding	Warning	Tachograph	The vehicle speed has exceeded the speed limit set for 1 minute and will be stored.	▶ Observe the specified speed limit.
>>? Overspeeding pre-warning	Message	Tachograph	The vehicle is exceeding the over speed limit set. After 1 (one) minute of continuous over speeding the warning will be stored.	▶ Observe the specified speed limit.
! † Power supply interruption	Warning	Tachograph	The tachograph supply voltage is below or above the limit for correct operation or has been disconnected.	▶ Visit a digital tachograph workshop if the reason for the message is unknown.
▼ ↑ o Printer high temperature	Message	Printer	The printing could not start, or the ongoing printing has been interrupted, because the temperature of the printer is too high.	<ul style="list-style-type: none">▶ Wait until the printer temperature is in allowable range and try to print again.▶ If the printer still fails, visit a digital tachograph workshop to have the equipment checked.

Messages, Warnings and Malfunctions

Display	Type	Unit	Description	Action
▼ ↓ † Printer low power	Message	Printer	The ongoing printing has been interrupted because the tachograph input voltage is too low.	<ul style="list-style-type: none"> ▶ Check the vehicle battery voltage, connections, etc. ▶ If the printer still fails, visit a digital tachograph workshop to have the equipment checked.
▼ ↓ ○ Printer low temperature	Message	Printer	The printing could not start because the temperature of the printer is too low.	<ul style="list-style-type: none"> ▶ Wait until the printer temperature is in allowable range and try to print again. ▶ If the printer still fails, visit a digital tachograph workshop to have the equipment checked.
▼ Ⓟ × Printer out of paper	Message	Printer	The ongoing printing has been interrupted because the printer is out of paper.	<ul style="list-style-type: none"> ▶ Replace paper.
Printing busy 	Message	Printer	The printing is ongoing.	<ul style="list-style-type: none"> ▶ Wait until the printout is finished. ▶ Press and hold  to cancel the printout
▼ ○ ▼ Printing cancelled	Message	Printer	The ongoing printing has been cancelled.	<ul style="list-style-type: none"> ▶ No further action required.

Displays and Data

Messages, Warnings and Malfunctions

Display	Type	Unit	Description	Action
▼ ✓ ▼ Printing complete	Message	Printer	The ongoing printing has been completed.	▶ No further action required.
>4 1/2h? Quarter left reminder	Message	Tachograph	The driver has 15 minutes left until the legal maximum continuous driving time of 4½ hours will be exceeded.	▶ Find a suitable place to take a break in the next 15 minutes.
! Ⓜ Ⓜ Sensor auth. failure	Malfunction	Sensor	The tachograph does not detect the motion sensor.	▶ Visit a digital tachograph workshop to have the equipment checked.
! Ⓜ Ⓜ A Sensor auth. failure	Malfunction	Sensor	The tachograph does not recognise the connected motion sensor as the one installed.	▶ Visit a digital tachograph workshop to have the equipment checked.
! Ⓜ =0 Sensor cable fault	Warning	Sensor	Motion sensor data error.	▶ Visit a digital tachograph workshop to have the equipment checked.
! Ⓜ >0 Sensor cable fault	Warning	Sensor	Motion sensor data error.	▶ Visit a digital tachograph workshop to have the equipment checked.
× Ⓜ A Sensor comms error	Malfunction	Sensor	Motion sensor communication error.	▶ Visit a digital tachograph workshop to have the equipment checked.

Messages, Warnings and Malfunctions

Display	Type	Unit	Description	Action
! 0 Sensor data error	Warning	Sensor	Appears for one of the following reasons: No Speed signal from Sensor. Invalid speed signal or data link error. Speed Sensor – VU signature mismatch.	► Visit a digital tachograph workshop to have the equipment checked.
! 0 1 / 1 Sensor data integrity error	Mal-function	Sensor	Internal sensor error, stored data integrity failure.	► Visit a digital tachograph workshop to have the equipment checked.
! 0 → 1 x Sensor data transfer error	Mal-function	Sensor	The speed sensor and tachograph do not communicate.	► Visit a digital tachograph workshop to have the equipment checked.
x 1 Sensor fault	Mal-function	Sensor	A data link error between the speed sensor and the tachograph.	► Visit a digital tachograph workshop to have the equipment checked.
x 1 ✓ Sensor fault no acknowledge	Mal-function	Sensor	Motion sensor communication error.	► Visit a digital tachograph workshop to have the equipment checked.
x 1 ← 1 Sensor fault no answer	Mal-function	Sensor	Motion sensor communication error.	► Visit a digital tachograph workshop to have the equipment checked.

Displays and Data

Messages, Warnings and Malfunctions

Display	Type	Unit	Description	Action
×A ⏏ ↑ Sensor fault power high	Mal-function	Sensor	Sensor power too high.	▶ Visit a digital tachograph workshop to have the equipment checked.
×A ⏏ ↓ Sensor fault power low	Mal-function	Sensor	Sensor power too low.	▶ Visit a digital tachograph workshop to have the equipment checked.
! ⏏ ↑ Sensor no power signal	Mal-function	Sensor	Sensor has no power.	▶ Visit a digital tachograph workshop to have the equipment checked.
! ⏏ < × Sensor unauth. case open	Mal-function	Sensor	Unauthorized opening detected.	▶ Visit a digital tachograph workshop to have the equipment checked.
A → T? Service pre-warning	Message	Tachograph	Next calibration, pre-warning.	▶ Visit a digital tachograph workshop to have the equipment checked.
>4 1/2h Time for break reminder	Message	Tachograph	The legal maximum continuous driving time of 4½ hours has elapsed.	▶ Stop the vehicle at the earliest opportunity and take a break.
! A → T Time for service	Message	Tachograph	The tachograph is out of calibration.	▶ Visit a digital tachograph workshop to have the tachograph re-calibrated.
■ → Ⓞ Timeout no key pressed	Message	Tachograph	The tachograph is waiting for input.	▶ Press the appropriate buttons and complete the process.

Messages, Warnings and Malfunctions

Display	Type	Unit	Description	Action
!⊗ UTC adjust not allowed	Message	Tachograph	UTC time adjustment more than +/- 1 (one) minute once a week is not allowed.	<ul style="list-style-type: none"> ▶ If the UTC time in the tachograph has deviated by more than 20 minutes, it must be calibrated by a digital tachograph workshop.
×⊠/⊡∠* Unable to open slot	Message	Tachograph	The card tray concerned cannot be opened.	<ul style="list-style-type: none"> ▶ Check the tray for correct operation. ▶ If the tray still fails, visit a digital tachograph workshop to have the equipment checked.
!⊠⊠⊠ Unauth. change of sensor	Mal-function	Sensor	The sensor has been changed since last pairing.	<ul style="list-style-type: none"> ▶ Visit a digital tachograph workshop to have the equipment checked.
!A∠x Unauth. VU opening	Mal-function	Tachograph	The tachograph unit case has been opened.	<ul style="list-style-type: none"> ▶ Visit a digital tachograph workshop to have the equipment checked.
×A VU internal fault	Mal-function	Tachograph	The tachograph (VU) has detected an internal malfunction.	<ul style="list-style-type: none"> ▶ Visit a digital tachograph workshop to have the equipment checked.

Changing the Paper Roll

Maintenance and Care

Built-in Test

Frequently asked Questions

Changing the Paper Roll

Remove the Paper Cassette

- ▶ Press the upper edge of the front panel. The panel folds out.



- ▶ Hold the panel by the lower edge.

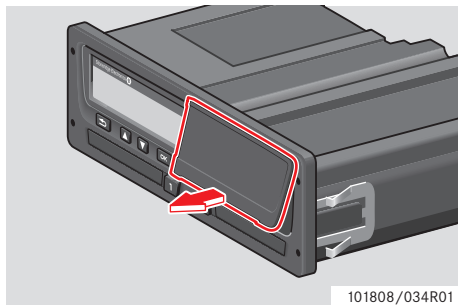

101808/034R01

- ▶ Pull the paper cassette out carefully.

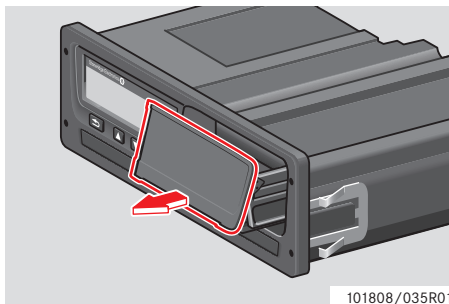

101808/035R01

Insert a Paper Roll

!

Only use printer paper approved by Stoneridge, otherwise there is a risk of printer malfunctions.

- ▶ Insert the paper roll. Feed the paper around the back of the paper cassette and forwards, passing the lower edge of the panel.

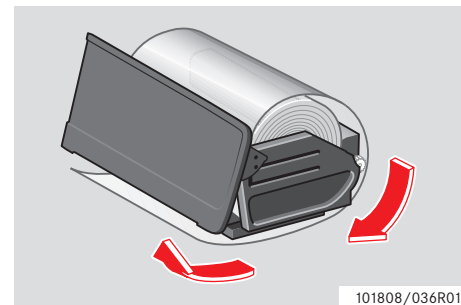

101808/036R01

Changing the Paper Roll

- ▶ Insert the paper cassette into the printer fixtures.
- ▶ Press the middle of the panel and slide the paper cassette into the tachograph until it engages.

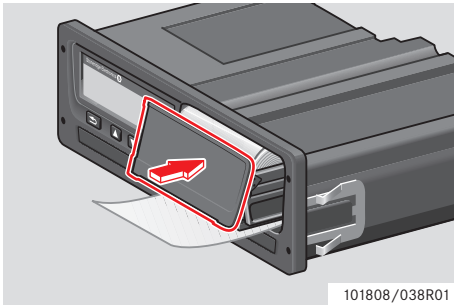

- ▶ Pull the paper upwards and tear it off.

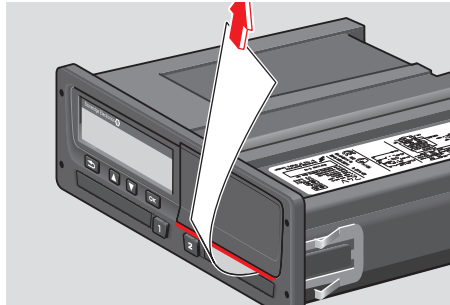

Maintenance and Care

Replacement Parts for Printer

Contact the local representative if there is a need of replacement parts.

Replacement part	Part No.
Paper roll - 3 pack	6800-032
Paper roll - 8 pack	6800-002
Paper cassette	6800-001



Store the printer paper in a cool, dry and dark location.

Care for card

Care for card:

- Do not flex or bend the card.
- Ensure that the card contacts are kept free from dirt and dust.
- Clean it with a soft damp cloth if necessary.
- Protect it from theft, loss and damage.

Driver Card damaged, lost or stolen

If the driver card is damaged, lost or stolen the owner has to request a replacement card at the responsible authority, in the country where the card was issued. If a driver card is stolen or if the owner suspects that an unauthorized person has access to it, the owner has to report the incident to the police in the area and obtain a police report number.



A driver without a valid driver card is not permitted to drive a vehicle equipped with a digital tachograph.

Please consult the country's authority for national regulations.

Maintenance and Care

Care for tachograph

Care for the tachograph:

- Do not place objects on the trays when they are open, otherwise they could be damaged.
- The ingress of dirt can lead to premature failure of the tachograph.
- Keep the trays closed at all times and only open them to insert and withdraw a card.
- Clean a dirty tachograph with a damp, soft cloth.

Avoid High Voltage

Interrupt the power supply to the tachograph if you expect that the vehicle will require several jump-starting attempts.

For more information on how to interrupt the tachograph power, see the vehicle's operating manual.

It might be necessary to re-calibrate the tachograph if the power is interrupted.

!

High voltage may lead to permanent tachograph damage and to failure of the tachograph's electronic components. Damage to the tachograph caused in this way invalidates the warranty.

Built-in Test

Built-in Test

The built-in test is only possible when the vehicle is stationary. This test allows the driver to check the following tachograph components for correct operation:

⌘	Invert display
□	Display
■	Driver card
ƒ	Buttons
▼	Printer

- 1 Press the **OK** button.
- 2 Use the **▼** or **▲** button to select “SETTINGS” and press **OK**.



- 3 Use the **▼** or **▲** button to select “Built-in test” and press **OK**.



- 4 Use the **▼** or **▲** button to select what test to perform and press **OK**.

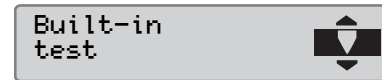
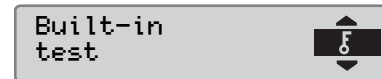
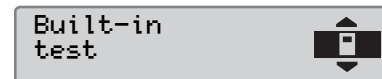
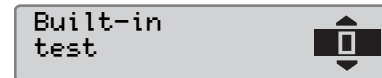
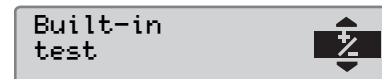

Built-in Test

Symbol	Test	Description	Action if the test fails
↺	Invert display	Invert display function test The display view is inverted for 2 seconds.	▶ Visit a digital tachograph workshop to have the tachograph checked if the display is unreadable.
□	Display	Display test The display is illuminated for 1 second and goes out for 1 second. A pattern of rectangles is then displayed for 1 second.	▶ Visit a digital tachograph workshop to have the tachograph checked if the display is unreadable.
■	Driver card	Test of the inserted driver cards There must be a driver card in the relevant slot. The name of the card holder is read and displayed for 2 seconds.	<ul style="list-style-type: none"> ▶ If a driver card is reported as defective, check a different driver card to ensure that the tachograph is functioning. ▶ If the tachograph seems to be defective, visit a digital tachograph workshop to have the equipment checked. ▶ If it is the driver card that is definitely defective, contact the responsible authority in the country where the driver card was issued.

Symbol	Test	Description	Action if test failed
⌘	Buttons	Button test You are prompted to press the buttons one by one from left to right within 2 seconds of each other, otherwise the test fails.	<ul style="list-style-type: none">▶ Carefully clean dirty buttons with a damp cloth and a mild detergent.▶ Visit a digital tachograph workshop to have the tachograph checked if a button repeatedly fails to work.
▼	Printer	Test page printed out	<ul style="list-style-type: none">▶ Check the paper cassette, if necessary insert a new paper roll or replace the cassette.▶ Visit a digital tachograph workshop to have the tachograph checked if the printer still does not work.

Frequently asked Questions

Frequently asked Questions

Frequently asked questions	Answers
How do I insert and eject a driver card?	<p>Press and hold the ▲ or ▼ button for at least three seconds and the card tray will eject.</p> <p>To remove the card from the tray, press the driver card up slightly from underneath through the opening in the tray or push the edge of the tray down until the card pops out. (Ejecting a card can only be done when the vehicle is stationary.)</p>
How do I take a 24 h print out from the drivers card?	<p>Press the OK button once to go to the print screen. Press OK once more and use the ▲ and ▼ buttons to select the printout you want. To confirm and to activate the printout, press OK.</p>
How do I print local time 24h printout?	<p>Press the OK button once to get to the printing menu. Press the OK button once more. Use the ▲ and ▼ buttons to select the print-out you want. Commence the selected printout by pressing OK.</p>
How do I select language on the tachograph?	<p>Press the OK button. Use the ▲ and ▼ buttons to select Settings and press OK. Use the ▲ and ▼ buttons to select language and press OK. Use the ▲ and ▼ buttons to select your language and press OK.</p>
How do I select the activity on the tachograph?	<p>Press the ▲ or ▼ button. The selectable modes are Available, Other work and Rest/break. Drive is automatically selected when the vehicle is set in motion.</p>

Frequently asked questions	Answers
How do I set the display the local time.	Navigate to the settings by pressing the OK button from main screen. Next, use the ▲ and ▼ buttons to scroll to the settings menu. Press OK to access the settings menu and the ▲ and ▼ buttons to scroll to local time and confirm with OK . You can alter the time in steps of 30 minutes. Press OK to confirm.
How do I replace the printer paper?	Remove the front cover on the right-hand side of the tachograph by pressing the top of the plastic cover. This will dislodge the cover and allow you to pull the roll.
How can I quickly check that the VU is working fine?	Press the OK button once and then use the ▲ and ▼ buttons to navigate to “Settings”. In the “Settings” menu you can select “Built in test” to carry out a working test on your SE5000.
How do I change to Ferry/Out of Scope mode?	Press the OK button once and then use the ▲ and ▼ buttons to navigate to “Places”. In the “Places” menu you can select “Ferry” or “Out of Scope”.
How do I download data from the SE5000? (Company mode)	Ensure you have a valid Company card inserted and locked into the tachograph. See Company locks. Connect a type approved Download tool to retrieve the data.
How do I lock in the Company data? (Company mode)	Insert the Company card then press OK to enter the menu. Use the ▲ and ▼ buttons to select “Company locks” and confirm with pressing OK .
When am I required to lock in the Company data? (Company mode)	The first time you take delivery of the vehicle you need to insert your Company card to lock in the data.

Frequently asked Questions

Frequently asked questions	Answers
Where is the download connector? (Company mode)	The connector is located on the left side of the paper roll behind the plastic cover.

Available Countries

Available Languages

ADR Tachograph

Data stored on Driver Card and in Tachograph

National Importers

Time Zones

Appendix

Available Countries

Available Countries

The tachograph enables the following countries to be selected as location.

Country
Albania
Andorra
Armenia
Austria
Azerbaijan
Belarus
Belgium
Bosnia and Herzegovina
Bulgaria
Croatia
Cyprus
Czech Republic
Denmark
Estonia
European Community

Country
Faeroe Islands
Finland
France
Georgia
Germany
Greece
Hungary
Iceland
Ireland
Italy
Kazakhstan
Latvia
Liechtenstein
Lithuania
Luxembourg

Country
Macedonia
Malta
Monaco
Netherlands
Norway
Poland
Portugal
Republic of Moldova
Rest of Europe
Rest of the World
Romania
Russian Federation
San Marino
Slovakia
Slovenia

Available Countries

Country	Spanish regions
Spain, see Spanish regions beside.	Andalucía
Sweden	Aragón
Switzerland	Asturias
Turkey	Balears
Turkmenistan	Canarias
Ukraine	Cantabria
United kingdom, including: <ul style="list-style-type: none"> <li data-bbox="103 521 236 546">• Alderney, <li data-bbox="103 566 240 591">• Guernsey, <li data-bbox="103 611 204 636">• Jersey, <li data-bbox="103 656 261 680">• Isle of Man, <li data-bbox="103 701 233 725">• Gibraltar 	Castilla-La-Mancha
	Castilla-León
	Cataluña
	Extremadura
	Galicia
	La Rioja
	Madrid
	Murcia
	Navarra
	País Vasco
	Valencia

Available Languages

The tachograph by default uses the driver card language in the tachograph language.

The tachograph and printout language can be changed to one of the following languages.

Language	
Български	Bulgarian
Cesky	Czech
Dansk	Danish
Deutsch	German
Eesti	Estonian
Ελληνικά	Greek
English	English
Español	Spanish
Français	French
Íslenska	Icelandic
Italiano	Italian
Latviesu	Latvian

Language	
Lietuviu	Lithuanian
Magyar	Hungarian
Nederlands	Dutch
Norsk	Norwegian
Polski	Polish
Română	Romanian
Русский	Russian
Português	Portuguese
Slovenčina	Slovakian
Slovenscina	Slovenian
Suomi	Finnish
Svenska	Swedish

ADR Tachograph

ADR Tachograph

Approved for Use in Hazardous Goods Vehicles

The ADR version of the tachograph is approved for use in hazardous goods vehicles.

It differs from the standard tachograph as it has explosion protection and is certified in accordance with EU Directive 94/9/EC.

TÜV test certificate number:

ATEX 2507 X, with corresponding supplements.

(TÜV= Technischer Überwachungs Verein)

!

The ADR tachograph explosion protection is only guaranteed when the vehicle is stationary and the battery isolating switch is open.

Special features of the ADR Tachograph

For the ADR tachograph some functions are disabled immediately when the ignition is switched off:

- Card trays cannot be ejected.
- Printouts are not possible.
- Background illumination for buttons and display is switched off.



The ADR tachograph will enter the power saving mode immediately after the ignition is switched off.

To have the ADR tachograph fully operational, the ignition key must be in position key-on or ignition on, depending on vehicle manufacturer.

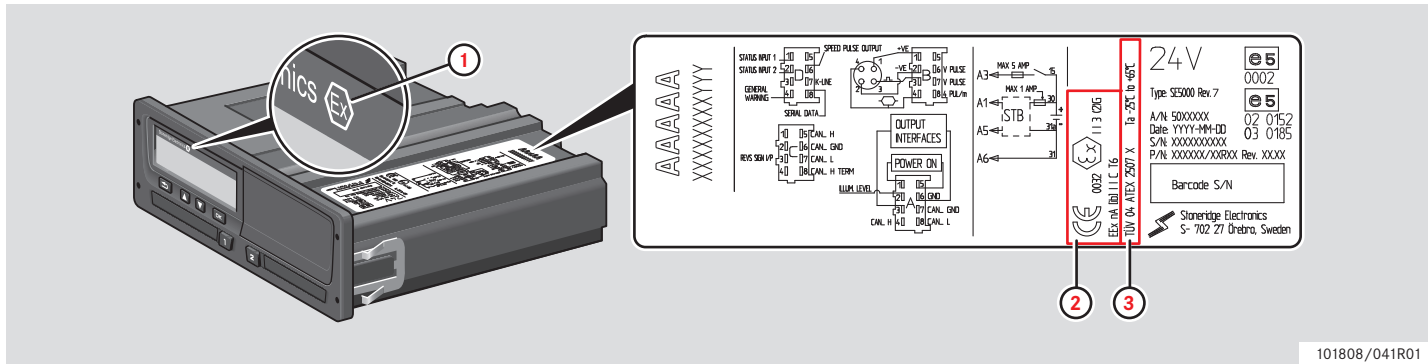

Visible differences between a standard tachograph and an ADR tachograph

- 1 "Ex" symbol on the tachograph front
- 2 ADR classification
- 3 TÜV test certificate number

Data stored on Driver Card and in Tachograph

Data stored on Driver Card and in Tachograph

Various data is stored on the driver card and in the tachograph respectively for each:

- Day
- Driver
- Vehicle
- Change of activity

Data Stored on Driver Card

Data is stored on the driver card when:

- A driver card is inserted or withdrawn from the tachograph.
- The driver activity changes or is manually entered.
- Warnings and malfunctions occurs.
- Controls are performed by authorities.

In case of two drivers, each driver's card data is stored only on respective card.

Insertion and Withdrawal Data

Data stored for each day and vehicle:

- Date and time for the first driver card insertion and last withdrawal.
- Vehicle odometer value at first driver card insertion and last withdrawal.
- The vehicle registration number and registering member state of the vehicle.

Driver Activity Data

Data stored for each day and change of driving activity:

- Date and daily presence counter.
- The total distance travelled by the driver card holder.
- The driving status at 00:00 hours or at card insertion, single driver or part of a crew.
- A record of each driving activity change:
- Driving status: driver or co-driver.
- Card tray used in the tachograph.
- Card inserted or not inserted at the time of change of activity.
- Driver activity.
- Date and time of activity change.

Data Stored in Tachograph

Data is stored in the tachograph when:

- A driver card is inserted or withdrawn.
- The driver changes activity.
- Events and malfunctions occurs.
- Tampering with the tachograph.

Vehicle speed is stored continuously.

Insertion and Withdrawal Data

Data stored for each driver card:

- Card holder's surname and first name.
- Driver card number, card issuing member state and the card expiry date.
- Date and time at driver card insertion and withdrawal.
- Vehicle odometer value at driver card.
- Insertion and withdrawal time.
- The vehicle registration number and registering member state of the vehicle.
- Card withdrawal time for the last vehicle in which the driver card was inserted.
- In which tray the driver card is inserted.
- Indication if manual entries of activities have been made.
- Driver's tachograph language choice.

Driver Activity Data

Data stored for each day and change of driving activity:

- Driving status: single or part of a crew.
- Card tray used in the tachograph.
- Card inserted or not inserted at the time of change of activity.
- Driver activity.
- Date and time of activity change.

Other Data

Other data stored in the tachograph:

- Detailed vehicle speed.
- Vehicle overspeeding for at least 1 minute.
- Company and workshop events.

National Importers

National Importers

National Importers

National importers can be found in the list below.

Contact the local representative for information, support or replacement parts.

Country	Importer	Phone number	Address
Australia	Mobile Instrument Service Pty Ltd	Phone: +61 02 9621 8190 Fax: +61 02 9676 7297	13/11 Bowmans Rd, 2148 Kings Park, New South Wales, Australia E-mail: mispl@iprimus.com.au
Austria	See Germany		
Belarus	See Russia		
Belgium	Phelect SRPL	Phone: +32 (8) 7560 274 Fax: +32 (8) 7560 273	Zoning Industriel des Plénesses, Route des 3 Entités, 15, 4890, Thimister-Clermont, Belgium E-mail: info@phelect.be
Bosnia-Herzegovina	See Croatia		
Bulgaria	Globus Commerce Ltd	Phone: +359 028 403 226 Fax: +359 028 403 194	Angel Voivoda Str 47. 126, 1510, Sofia, Bulgaria E-mail: globus@globuscommerce.com Website: http://www.globuscommerce.com

Appendix

National Importers

Country	Importer	Phone number	Address
Canada	Canadian Automotive Instruments Ltd	Phone: +1 780 963 8930 Fax: +1 780 963 8230	33 Boulder Blvd, T7Z 1V6 Stoney Plain, Alberta, Canada E-mail: sales@c-a-i.net Website: http://www.c-a-i.net
Chile	TAFCK Servicio Intrumental Automotriz	Phone: +56 5225 174, 5248 680, 4165 887 Fax: +56 4161 679	Jose Joaquin Prieto, 4960 San Miguel, Santiago, Chile Email: tacographos@tafck.cl Webbsite: http://www.intrumentalautomotriz.cl
China	Stoneridge Asia Pacifick Electronics (Suzhou) Co. Ltd	Phone:+86 512 6286 2188 fax: +86 512 6715 2128	268 ThangZuang Road, Loueng North District SIP, 215001, Suzhou, JiangSu,PR China E-mail: info@stoneridge.com Website: www.stoneridge.com
Croatia	Auto Konzalting D.O.O.	Phone: +385 (0)1 307 7124 Fax: +385 (0)1 307 7124	Hanamanova 26, HR-1000 Zagreb, Croatia E-mail: auto-konzalting@zg.htnet.hr Website: http://www.usteda-goriva.hr
Cyprus	K A Hiras Parts Ltd.	Phone: +357 (0)25 571 230 Fax: +357 (0)22 575 667	Soudas 16B, CY-3048 Limassol, Cyprus E-mail: k.a.hiras@cytanet.com.cy Website: http://www.hirasparts.com
Czech Republic	HALE spol. s r o.	Phone: +420 (0)283 870 676 Fax: +420 (0)283 870 091	Dělnická 15, CZ-170 00 Praha 7, Czech Republic E-mail: halesro@hale.cz Website: http://www.hale.cz

National Importers

Country	Importer	Phone number	Address
Denmark	BG Service Center A/S	Phone: +45 (0)87 418010 Fax: +45 (0)87 418011	Grenåvej 148, DK-8240 Aarhus, Denmark E-mail: jk@bgteknik.com. Website: http://www.bgdk.dk
Estonia	Lajos Ltd	Phone: +372 3270 940 Fax: +372 3270 941	Jaama 16, 44106 Kunda, Lääne Virumaa Estonia E-mail: lajos@lajos.ee, priit@lajos.ee Website: http://www.lajos.ee
Finland	Piirla Oy	Phone: +358 (0)17 283 1595 Fax: +358 (0)17 283 1644	Hopeakatu 4, FI-70150 Kuopio, Finland E-mail: piirla@piirla.fi Website: http://www.piirla.fi
France	Stoneridge Electronics	Phone: +33 (0)5 5950 8040 Fax: +33 (0)5 5950 8041	Adress1: Zone Industrielle de St Etienne, Chermin de CasenaveFR-64100, Bayonne, Aquitaine, France E-mail: france.amsales.@stoneridge.com Website: http://www.stoneridgeelectronics.info
Germany	IVEKA Automotive Technologies Schauz GmbH	Phone: +49 (0)7041 96950 Fax: +49 (0)7041 969555	Talweg 8, DE-75417 Mühlacker, Baden Württemberg, Germany E-mail: info@iveka.de Website: http://www.iveka.de
Greece	P. Theodosiou Ltd	Phone: +30 (0)210 3474500 Fax: +30 (0)210 3477315	115 Athinon Av, GR-104 47 Athens, Greece E-mail: theodos@acsmi.gr
Holland	See Netherlands		

Appendix

National Importers

Country	Importer	Phone number	Address
Hungary	Szelpo AutoControl Systems Kft.	Phone: +36 (0)22 500 863 Fax: +36 (0)22 500 862	8000 Székesfehérvár, Budai út 390, Hungary E-mail: szelpo@szelpo.hu Website: http://www.szelpo.hu
Iceland	Heckla hf	Phone: +354 (0)590 5100 Fax: +354 (0)590 5101	Klettagardar 10, IS-104 Reykavik, Iceland E-mail: obj@hekla.is Website: http://www.hekla.is
Ireland	MMC Commercials Ltd	Phone: +353 (0)1 419 2300 Fax: +353 (0)1 450 1035	John F Kennedy Drive, Naas Road, Dublin 12 , Republic of Ireland
Israel	Tachograph Ltd	Phone: +972 (0)3 550 7254 Fax: +972 (0)3 559 6891	25 Hapeled St, Holon, 58815 Israel E-mail: pniel_m@netvision.net.il Website: http://www.speedometer.co.il
Italy	Stoneridge Electronics s.r.l.	Phone: +39 0 650861001 Fax: +39 0 650861006	Viale Caduti nella Guerra di Liberazione, 568 00128 Rome, Italy E-mail: italy.amsales@stoneridge.com
Jordan	Saba Trading Est	Phone: +962 (0)6 416 6264 Fax: +962 (0)6 416 5835	25 AK Hadeed Street, POBox 925964, Umheeran, Amman, 11190 Jordan E-mail: sabatrd@wanadoo.jo
Kazakhstan	TOO “Trans-Takhograf”	Phone: +7 87 182 450 391 Fax: +7 87 182 327 556	Room 120, 99 AkademikaMargulana str, 140000, Pavlodar, 140011, Kazakhstan E-mail: trantsahograf@rambler.ru
Kosovo	See Croatia		

National Importers

Country	Importer	Phone number	Address
Latvia	Nordtranselektro SIA	Phone: +371 6756 3753 Fax: +371 6756 3753	Braslas 22, LV1035, Riga, Latvia E-mail: ntrans@ilad.lv Website: http://www.tahograf.lv
Lithuania	Vectis UAB	Phone: +370 473 111 Fax: +370 473 141	Armoniškiu 37, 46401, Kaunas, Lithuania E-mail: vectis@vectis.lt Website: http://www.vectis.lt
Luxembourg	See Germany		
Macedonia	See Croatia		
Malta	Ucimco Overseas Ltd	Phone: +356 (0)23 821 551 Fax: +356 (0)21 492 699	Ucimco Buildings, Valley Road, B'Kara, BKR14 Malta E-mail: pcass@pater.com.mt
Moldova	Caterpillar	Phone: +373 (0)22 506 910 Fax: +373 (0)22 506 910	Str Paduri 22, Chisinau2002, Moldova E-mail: office@caterpillar.md Website: caterpillar.md
Montenegro	See Croatia		
Morocco	Egloffé Controle Maroc	Phone: +212 02 224 8380	Rond Point Aïcha, Rond Point Aïcha, 20330 Belvédère, Casablanca, Morocco
Morocco	Sara Electronique	Phone: +212 02 262 3637	67 Rue Abou Youssef El Mesdaghi, 20300 La Villette, Casablanca, Morocco

Appendix

National Importers

Country	Importer	Phone number	Address
Netherlands	C.A.S.U. Utrecht b. v.	Phone: +31 (0)30 288 4470 Fax: +31 (0)30 289 8792	Ravenswade 118 (Industrieterrein de Liesbosch) NL-3439 LD Nieuwegein, Netherlands E-mail: info@casuutrecht.nl Website: http://www.casuutrecht.nl
New Zealand	Mobile Instrument Service Pty Ltd	Phone: +61 (0)2 9621 8190 Fax: +61 (0)2 9676 7297	13/11 Bowmans Rd, 2148 Kings Park, New South Wales, Australia E-mail: mispl@iprimus.com.au
New Zealand	Robinson Instruments Ltd	Phone: +64 (0)9 377 1565 Fax: +64 (0)9 358 0573	3/31 Princes Street, Onehunga , Auckland, 1061, New Zealand E-mail: sales@robinsoninstruments.co.nz Website: robinsoninstruments.co.nz
Norway	Instek A/S	Phone: +47 (0)628 16833 Fax: +47 (0)628 12250	Mårveien 6, Boks 1227, NO-2206 Kongsvinger, Norway E-mail: instek@instek.no Website: http://www.instek.no
Poland	Neris	Phone: +48 (0)22 662 2299 Fax: +48 (0)22 824 9777	Spisaka 90A, PL-02-495 Warszawa, Poland E-mail: neris@neris.pl Website: http://www.neris.pl/
Portugal	Lusilectra - Veiculos E Equipamentos Sa	Phone: +351 226 198 750	Rua Eng Ferreira Días 747 / 793,4100-247 Porto, Portugal

National Importers

Country	Importer	Phone number	Address
Romania	S C Fomco Prodimpex SRL	Phone: +40 265 318008 Fax: +40 265 318008	Str Ratul Mori 1295, Sangeorgiu de Mures, 547530, Romania E-mail: office@fomco.ro Website: http://www.fomco.ro
Russia	Awesto Holding Ltd	Phone: +7 (0)495 232 2111 Fax: +7 (0)495 232 2111	Ostapovsky proezd, 22 of 3, Moscow, 109316 Russia E-mail: avtermo@atom.ru Website: http://awesto.ru
Serbia	Univerzal Auto Tehnic Doo	Phone: +381 31 722 755 Fax: +381 32 722 756	Univerzal Auto Tehnic Doo1, Rudnichka Str, Gornji Milanovac, Serbia E-mail: univerzalat@alfagm.net
Slovenia	See Croatia		
South Africa	Automotive Control Systems	Phone: +27 (0)31 581 7300 Fax: +27 (0)31 563 1141	Unit 6 Reach Park, 28 Cordova Close, mBriardene Industrial Park, Durban, Kwa Zulu Natal, 4067 South Africa E-mail: mandy@acsystems.co.za Website: http://acsystems.co.zu
Spain	Stoneridge Electronics	Phone: +34 1 662 3222 Fax: +34 1 662 3226	Avda. Servero Ochoa 38 - Pol. Ind. Casa Blanca ES-28108 Alcobendas, Madrid, Spain E-mail: spain.amsales@stoneridge.com Website: http://www.stoneridgeelectronics.info

Appendix

National Importers

Country	Importer	Phone number	Address
Sweden	Stoneridge Nordic AB	Phone: +46 (0)8 154400 Fax: +46 (0)8 154403	Gårdsfogdevägen 18 A, SE-168 66 Stockholm E-mail: kontakt@stoneridge.com Website: http://www.stoneridgeelectronics.info
Switzerland	Auto Meter AG	Phone: +41 (0)41 349 4050 Fax: +41 (0)41 349 4060	Grabenhofstrasse 3, CH-6010 Kriens, Switzerland E-mail: info@autometer.ch Website: http://www.autometer.ch
United Kingdom	Stoneridge Electronics	Phone: +44 (0)871 700 7070 Fax: +44 (0)870 704 0002	Charles Bowman Avenue, Claverhouse Industrial Park, Dundee DDB 9UB, Scotland, UK E-mail: sales@elc.stoneridge.com Website: http://www.stoneridgeelectronics.info
Taiwan	TVI Company Ltd	Phone: +886 (0)2 2698 9638 Fax: +886 (0)2 2698 9056	9F-5, No.79 (FEWC / C-Building), Shin-Tai-Wu Road, Si-Jhih, Taipei County 22100, Taiwan E-mail: jonathen@cef.com.tw Website: http://www.cef.com.tw
Tunisia	Electro Diesel Tunisie	Phone: +216 071 333 066	9 Rue Hamouda Pacha, 1001, Tunis, Tunisia
Tunisia	MAP Services	Phone: +216 070 836 665	29 Rue de l'Artisanat, 2035 Ariana, Tunisia
Turkey	Olcusan Olcu Aletleri Sanayi Ve Ticaret A.S.	Phone: +90 0288 4361 165 Fax: +0288 4361 169	Buyukkaristiran Kasabasi, Kirklareli, 39780 Luleburgaz, Turkey E-mail: adnansarioglu@olcusan.com.tr Website: http://www.olcusan.com.tr

National Importers

Country	Importer	Phone number	Address
Ukraine	Arvest	Phone: +380 8 32 294 9392 +380 8 32 298 4500 Fax: +380 8 32 294 9390 +380 8 32 224 2161	Chornovola st.63 A/209, Lviv - 58, 79058, Ukraine E-mail: arvest@mail.lviv.ua Website: http://www.tacho.com.ua
USA	Zepco sales	Phone: +1 800 527 4305 Fax: +1 972 690 1061	508 North Central Expressway, Richardson, Texas, 75080, USA E-mail: mike@zepco.com

Time Zones

Time Zones

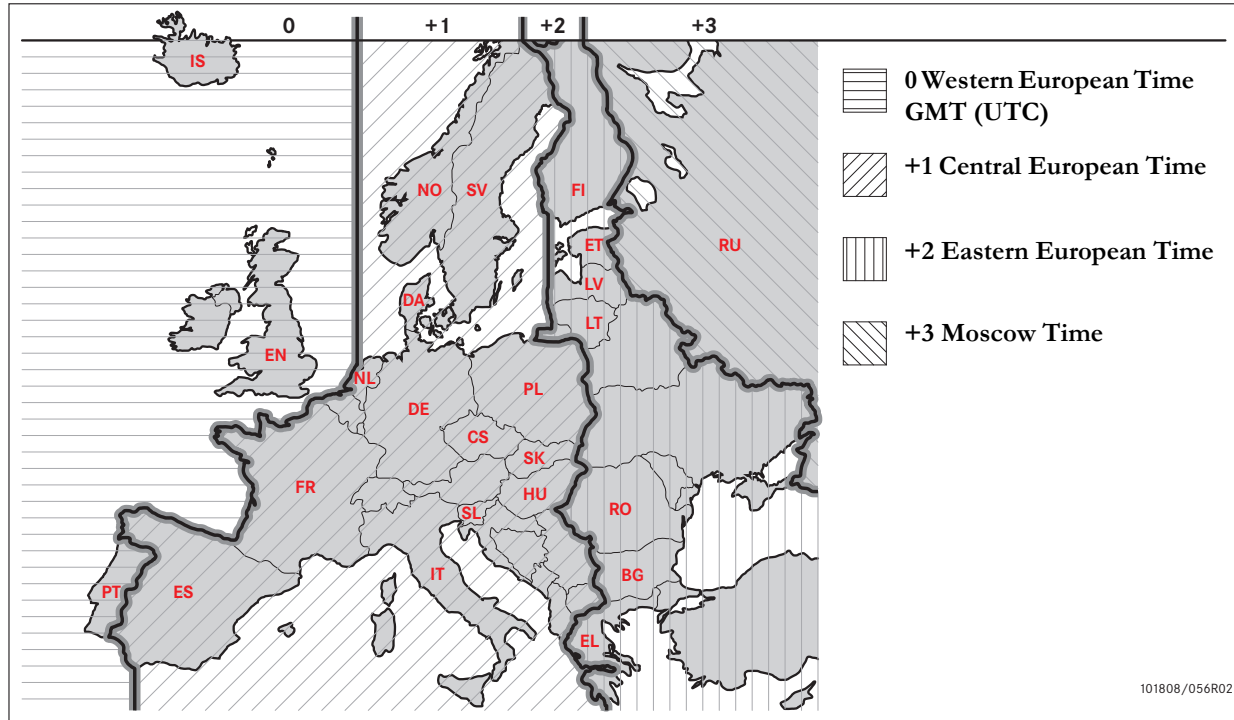

Requirements and Recommendations

Lock-in Data

Lock-out Data

Download Data

Settings

Tachograph Inspection

Requirements and Recommendations

Owner's Responsibility

It is recommended that the hauliers and vehicle owners ensure that their vehicles are fitted with a tachograph system according to EU and national laws.

Requirements

The following actions are recommended from hauliers and vehicle owners:

- Downloading data.
- Inspections.
- Storing of data.

Downloading Data

Hauliers and vehicle owners are required to download company specific data from the tachograph and from the driver card with enough regularity to ensure that no data risk getting overwritten.

Inspections

Hauliers and vehicle owners are responsible for:

- Company inspections - regularly performed on the vehicle's tachograph system.
- Workshop periodic inspection - the vehicle's tachograph system must go through an inspection at most every two years at a digital tachograph workshop.

Storing of Data

Hauliers and vehicle owners are recommended to:

- Store all downloaded data, with digital signatures, in a secure suitable way for archiving, to guard against equipment failure or data corruption in the main primary data store.
- Store all downloaded data in a secure way to prevent unauthorised access.
- Securely store any undownloadability certificates.
- Store test certificate after workshop periodic inspections in a secure location.



Consult the relevant authority for information about minimum storage period.

Requirements and Recommendations

Records

Hauliers and vehicle owners are required to:

- Keep a record of all tachograph data downloads.

Keep:

- Downloaded records
- Undownloadability certificates
- Workshop periodic inspection
- Certificates

available during any enforcement authority investigation or audit.

Recommendations

Hauliers and vehicle owners are recommended to perform the following:

- Lock data
- Certificates

Lock Data

- Lock-in of the data in the tachograph before a driver uses the vehicle.
- Lock-out of the data in the tachograph before transferring the vehicle to another company.

Certificates

- Keep a register of undownloadability certificates issued from a digital tachograph workshop.
- Ensure that the information in the tachograph test certificate received after a workshop periodic inspection is accurate.

Company Functions

With a valid company card inserted the following functions can be carried out:

- Lock-in data
- Lock-out data
- Download data

Lock-in Data

In order to prevent unauthorized persons from accessing the tachograph data, a lock-in must be performed before start using the tachograph.

Lock-out Data

A lock-out must be performed before transferring the tachograph to another user/owner. Otherwise, there is a risk of getting the next user's data recorded. If the download data procedure is forgotten the data will not be locked-out until the next user performs a lock-in.

Download Data

The tachograph data must be downloaded regularly to ensure that no data risk getting overwritten.

Settings

It is possible to preset the start/stop activity in key on/key off position.

Equipment Required

The equipment required for the company mode is:

- Tachograph
- Company card

Requirements and Recommendations

Tachograph

The tachograph records and stores data that can be shown in the display or on a print-out.

Vehicle information that can be shown is:

- RPM
- Vehicle speed
- D1/D2

Company Card

Company cards are issued by the responsible authorities in respective EU, EEA and AETR country.

A company may have several Company Cards.

The Company Card must be inserted in the tachograph in order to identify the company.

If the Company Card authentication fails, see page 81

The Company Card can be authenticated remotely. If remote authentication fails, the user will be notified by the user interface. This will not be visible on the VU-display.

The card tray is locked when the vehicle is in motion, while the tachograph is busy processing the company card and if the power supply to the tachograph is interrupted.

The Company Card can store a minimum of 230 records. The maximum number of records is dependent on the card type. When the upper limit is reached the oldest data will be overwritten.



EU - European Union
 EEA - European Economical Area
 AETR - United Nation's agreement on International Road Transport



It is very important to take care of company cards. If a company card falls into unauthorised hands, viewing and downloading of company locked data in any of a company's tachographs would be possible.

Download Equipment

Downloading of stored data from the tachograph memory or an inserted driver card is done by attaching a download equipment. For best result Stoneridge Electronics recommends OPTAC. Other download equipment compliant with the protocol as laid out in the legislative document 1360/2002 Annex 7 can also be used.

Lock-in Data

Lock-in Data

A lock-in must be performed before start using the tachograph, in order to prevent unauthorized persons from accessing the tachograph data.

Only data recorded after a lock-in will be locked and can then be downloaded or viewed only by the data owner.

Data recorded before a lock-in is accessible to all future users.

Company lock in/out

- 1 Insert a company card in tray 1 or 2.
The tachograph automatically enters the company mode of operation.
- 2 Press the **OK** button to enter the tachograph menu.
- 3 Use the **▲** or **▼** to select “COMP LOCKS” and press **OK**.

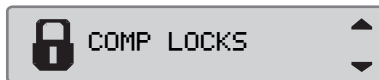

If the following display appears the data are locked-out.

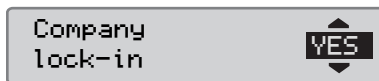

If the following display appears the data are locked-in.

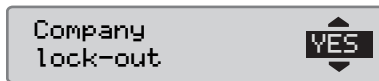

Another Company still Locked-in

If a lock-in is performed and there is another company still locked-in, the tachograph will automatically perform a lock-out of the previous company. No data will be lost for any company.

Lock-in Data

Perform Lock-in

To perform a lock-in of tachograph data a valid company card must be used.



If company cards are inserted in both trays, the last inserted card will be ejected.



Press the button to abort and return to the standard display.

- 1 Insert a company card in tray 1 or 2.
The tachograph automatically enters the company mode of operation.
- 2 Press the button to enter the tachograph menu.
- 3 Use the or to select “COMP LOCKS” and press .

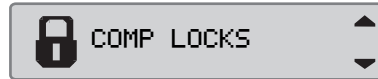

- 4 Use the or to select “YES”.

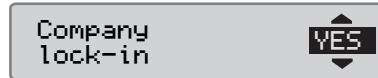

- 5 Press the to perform the lock-in.
The following display appears for a short time:

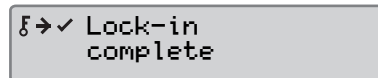

Lock-in is only possible if the present company is not already locked-in.



If the last lock-out was made by the present company, that lock-out will be cancelled and the present company lock-in will be extended to the date and time for the previous lock-in.



The tachograph is able to handle a maximum of 20 company locks. After that the oldest company lock will be removed.

Lock-out Data

A lock-out must be performed before the tachograph is transferred to another company or if there is a risk of getting the next company's data recorded. If the lock-out is forgotten, the data will not be locked-out until the next company performs a lock-in.

For information about the data stored during a company lock activity, see page 138.

Perform Lock-out

- 1 Insert a company card in tray 1 or 2.
The tachograph automatically enters the company mode of operation.
- 2 Press the **OK** button to enter the tachograph menu.
- 3 Use the **▲** or **▼** to select "COMP LOCKS" and press **OK**.

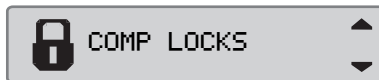

- 4 Use the **▲** or **▼** to select "YES".

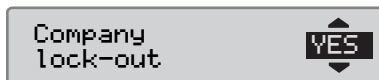

- 5 Press the **OK** to perform the lock-in.
The following display appears for a short time:



Download Data

Download Data

Downloading is the copying, together with a periodic digital signature, of a part or a complete set of data stored in a tachograph or on a driver card.

Regular downloading of data ensures that the company has a continuous record of driver and vehicle activity.

It is possible to download data remotely.

Data can be downloaded as many times as wanted. Company locked-in data can only be downloaded by the data owner.

Intervals for Download

Check with national authorities for guidelines.

Driver card Data

Data from a driver card does not have to be downloaded via the tachograph, it can be downloaded directly from the download equipment.

Store of Downloaded Data

All downloaded data should be stored:

- With digital signatures to be able to be checked for later validity.
- In a secure suitable way for archiving, to guard against equipment failure or data corruption in the primary data store.

Check with national authorities for guidelines.

Downloading Data



If a driver card is inserted in tray 1, insert the company card in tray 2 to perform the download.

- 1 Remove the printer cassette.
- 2 Attach the download equipment to the tachograph through the 6-way front download connector.

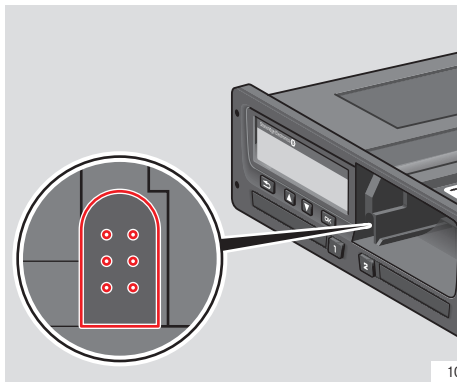

- 3 Start downloading data according to the instructions on the download equipment. The following message will be displayed indicating that the tachograph downloading is active.

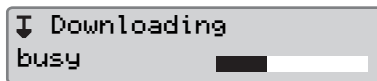

When downloading is completed, the following message will be displayed:



Data Download Failure

If the downloading process failed the tachograph's display will show the following warning:

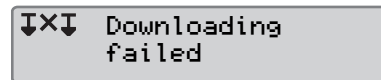

- ▶ Check the connections and the download equipment.

Tachograph faulty

If it is determined that the tachograph is faulty, the vehicle must be taken to a digital tachograph workshop for investigation.

Company Card faulty

If a company card is faulty, a replacement card must be used.

Download Data

Workshop Return of Downloaded Data

If a digital tachograph workshop decommissions a faulty tachograph it must download the data stored by the latest owner in the tachograph and return the data to the owner.

!

A workshop is not allowed to pass on company's downloaded data to a third party, without having a written permit from the company.

Certificate of Undownloadability

If it is not possible to download data from a faulty tachograph the workshop will issue a certificate of undownloadability.

Such certificate received from a workshop must be securely stored. The certificate must be available to the enforcement authorities during any investigation or audit.

It is good practice to keep a register of undownloadability certificates issued from a digital tachograph workshop.

i

If a workshop receives a written request from an enforcement authority, a copy of stored downloaded data might be given to the authority for the purpose of investigation without the permission of the data owner.

Download with Control Card

With a valid control card enforcement authorities can download data for investigation purposes.

Settings

Settings

Default activity key on

This setting gives the opportunity to preset an automatic activity change for both driver and co-driver when switching the ignition key on.

To preset the activity in key on:

- 1 Press the **OK** button.
- 2 Use the **▲** or **▼** to select “SETTINGS” and press **OK**.

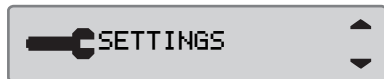

- 3 Use the **▲** or **▼** to select “Parameters” and press **OK**.

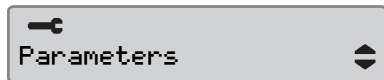

- 4 Use the **▲** or **▼** to select “Default activ. key on” and press **OK**.

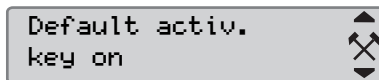

Use the **▲** or **▼** to select preferred activity.

- 5 Press **OK** to confirm. The following display appears.

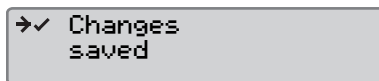

Press **⇒** three times to return to the standard display.

Default activity key off

This setting gives the opportunity to preset an automatic activity change for both driver and co-driver when switching the ignition key off.

To preset the activity in key off:

- 1 Press the **OK** button.
- 2 Use the **▲** or **▼** to select “SETTINGS” and press **OK**.

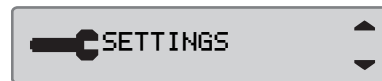

- 3 Use the **▲** or **▼** to select “Parameters” and press **OK**.

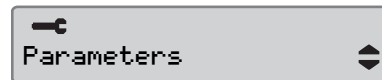

Settings

- 4 Use the **▲** or **▼** to select “Default activ. key off” and press **OK**.

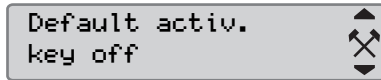

Use the **▲** or **▼** to select preferred activity.

- 5 Press **OK** to confirm. The following display appears.



- 6 Press **⇒** three times to return to the standard display.

Manual Entries time out

This setting gives the opportunity to preset the manual entries time-out from 1 minute (pre-set) or 20 minutes.

To preset the activity in key on:

- 1 Press the **OK** button.
- 2 Use the **▲** or **▼** to select “SET-TINGS” and press **OK**.



- 3 Use the **▲** or **▼** to select “Parameters” and press **OK**.

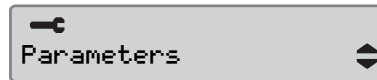

- 4 Use the **▲** or **▼** to select “Man. entries timeout” and press **OK**.



- 5 Use the **▲** or **▼** to select 1 minute or 20 minutes to time-out.

- 6 Press **OK** to confirm. The following display appears.

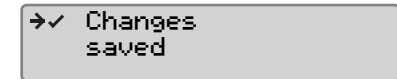

- 7 Press **⇒** three times to return to the standard display.

Drive Time warning

This setting gives the opportunity to set the tachograph to calculate the continuous drive time and cumulative rest time due to EC regulations 561/2006 or 3820/85.

To set the desired directive:

1 Press the **OK** button.

2 Use the **▲** or **▼** to select “**SETTINGS**” and press **OK**.



3 Use the **▲** or **▼** to select “**Parameters**” and press **OK**.

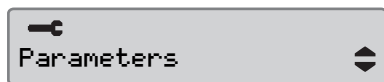

4 Use the **▲** or **▼** to select “**Drive time warning**” and press **OK**.

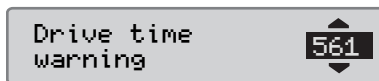

5 Use the **▲** or **▼** to select directive 561 or 3820.

6 Press **OK** to confirm. The following display appears.

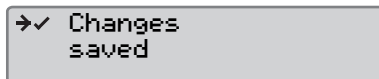

7 Press **↩** three times to return to the standard display.

Tachograph Inspection

Tachograph Inspection

A haulier or vehicle owner is responsible for regularly carrying out company inspections on the vehicles tachograph systems, to ensure that they adhere to the EU, EEA and AETR tachograph regulations.

The company inspection shall ensure that:

- The Type Approval Number is correct.
- The UTC time is accurate by less than 20 minutes.
- The tachograph is within the correct calibration interval.
- The installation plaque is time valid and not broken.
- The tamper label is not torn apart.

The company inspection should also ensure that:

- The stored calibration factors agree with what is recorded on the installation plaque.
- The tachograph's internally stored vehicle parameters (Vehicle Identification Number [VIN] and Vehicle Registration Number [VRN]) agree with the actual vehicle data.
- The tachograph has no visible damages.

Company Inspection Faulty

If there are discrepancies in any of the items included in a company inspection, or if there is any doubt regarding the company inspection the vehicle must be taken to a digital tachograph workshop for inspection. If not it will result in a decision that the company is breaking EU, EEA and AETR tachograph regulations and the vehicle, in which the tachograph is fitted, will be invalid for use.



Consult relevant authority for national regulations.

Company Functions Data

Record of Activity

When a company card is inserted into a tachograph in order to perform a lock-in/lock-out or a download, a record of card activity is stored on the company card and in the tachograph.

Each time a company card is used to carry out a company specific activity, such as locking or downloading, the following data is stored on the company card:

- Date and time of the company activity.
- Type of activity performed.
- Period downloaded, if applicable.
- VRN and country registration authority of the vehicle used for the activity.
- Driver card number and card issuing country, in case of a card download.

Company Card Stored Data

A single record of the company card activity, containing the following card and card holder information, will be stored on the company card:

- Card number.
- Issuing country, issuing authority name and the issue date.
- Card validity - start date and expiry date.
- Company name and address.

Tachograph Stored Company Activity Data

Each time a company card is used to carry out a tachograph activity a record is stored in the tachograph.

The data stored when performing a lock-in/lock-out is:

- Lock-in date and time.
- Lock-out date and time.
- Company card number and card issuing member state.
- Company name and address.

The data stored when performing a download is:

- Date and time of the download.
- Company card number.
- Card issuing member state of the card used to perform the download.

Index**A****Activities**

- Automatically selected23
- Change of, during working day23
- Definition20
- Manually selected23

ADR tachograph

- Special features109
- TÜV certificate109

B**Built-in test**98**Buttons**

- Back, see Return15
- Co-driver15
- Confirm, see OK15
- Down15
- Driver15
- OK15
- Return15
- Up15

C**Card Trays**15

- locked26

Certificate of undownloadability133**Certification** 10**Change of**

- Activity during working day 23
- Printer paper roll 94

Change to

- Tachograph menu 11

Co-driver

- Button 15
- Card tray 15

Company card 127

- faulty 132
- Mode functions 126

Company inspection 137

- Failed 137

Company mode of operation 132

- Download data 132
- Download failure 132
- Lock-in data 128
- Lock-out data 130

Control enforcement download 133**Country**

- Available in the tachograph 106

D**Definitions**

- Activities 20
- Working day 20

Display appearance

- Negative or positive view 71

Display in instrument cluster 13**Driver card**

- Damaged, lost, stolen 96
- Insert 20
- Withdraw 25

Driver Displays 74**E****Electromagnetic compatibility** 10**EU, EEA, AETR**

- Definitions 129

F**Ferry/train activity** 38**H****Hazardous goods tachograph**

- ADR Tachograph 109

I**Insert**

- Driver card 20
- Insert Driver Card 20
- Paper roll 94

Inspection

- Company 137
- Workshop 9

Installation plaque 9

L

Language 108

List of

Displays 75

Messages, warnings and malfunctions 79

Symbol combination 78

Symbols20, 76, 77

M

Manual entries

Manual entries with unaccounted time 31

Modify manual entries 34

Perform manual entries 27

Messages

List of 80

N

Normal working day 21

O

Operating Temperature 10

Out of scope driving 39

Overview

Tachograph System 12

P

Printer

Paper cassette 98

Printouts 41

Replacement part for printer 96

Printouts

Create 40

Show on display 41

Show on paper 41

Types of printouts 42

R

Return

Button 15

S

Self test

Built in test 98

Symbols

Description76, 77

System Overview

Tachograph 13

U

User interface 14

UTC-time 69

V

VU (Vehicle Unit)

See tachograph13

W

Working day

Change activity23

Normal21

Workshop

Return of downloaded data133





STONERIDGE - SETTING THE STANDARD

Stoneridge Electronics Ltd

Charles Bowman Avenue
Claverhouse Industrial Park
Dundee Scotland DD4 9UB

Tel: +44 (0)871 700 7070

Fax: +44 (0) 870 704 0002

E-mail: sales@elc.stoneridge.com

www.stoneridgeelectronics.info



102019P/01R02 EN